

# Tag der Forschung

## IKT – Süd 2008

---

**Rohrvortrieb:**

**Ergebnisse aus Großversuchen und  
In-situ-Untersuchungen**

**Dipl.- Ing. Martin Liebscher**

1. Hintergrund
2. Vortriebssimulator
3. Auswertung
4. Ausblick

# 1. Hintergrund

2. Vortriebssimulator

3. Auswertung

4. Ausblick



# Prinzipskizze Rohrvortrieb

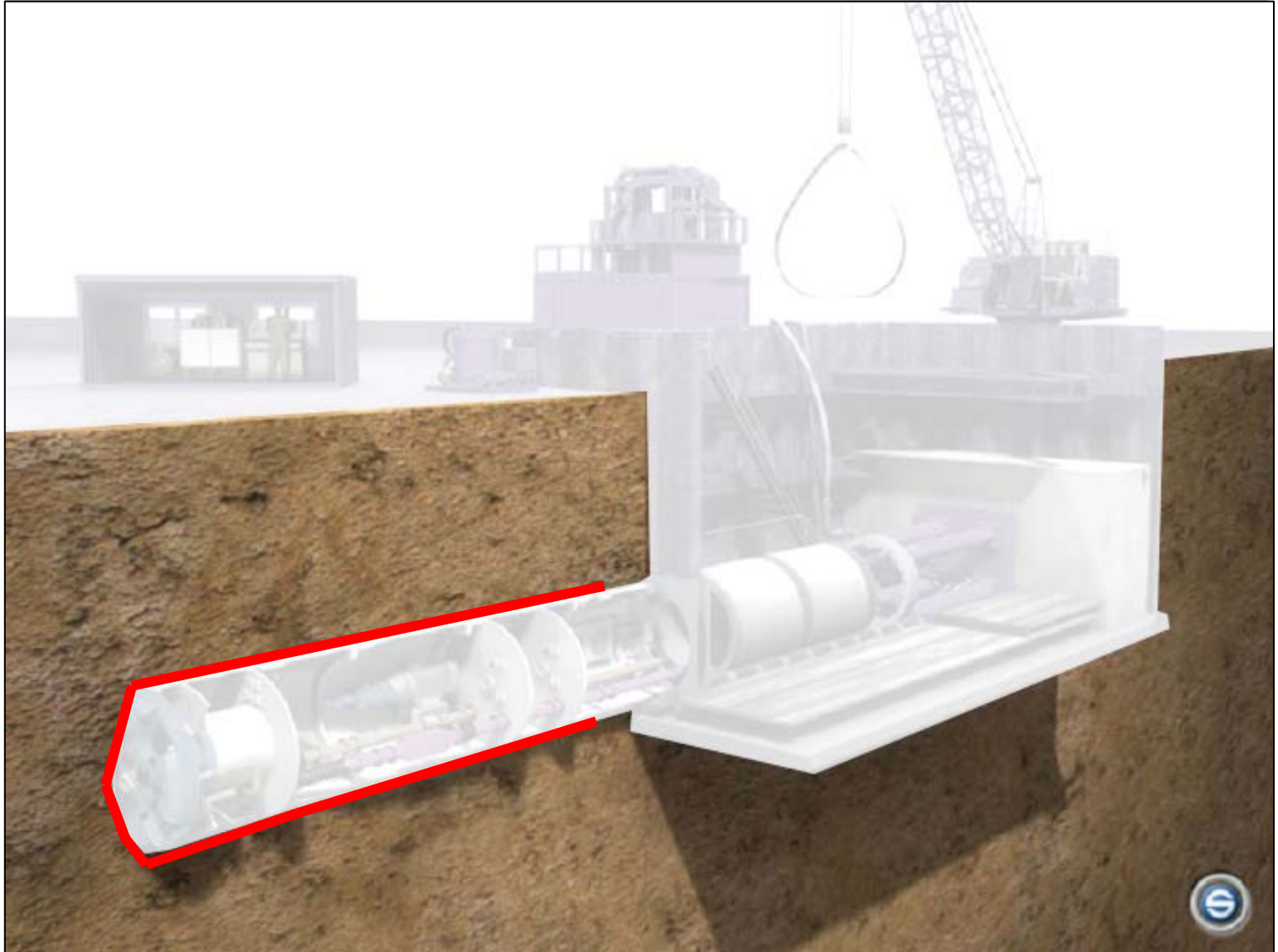

# Probleme und offene Fragen



# Rohrverbindung

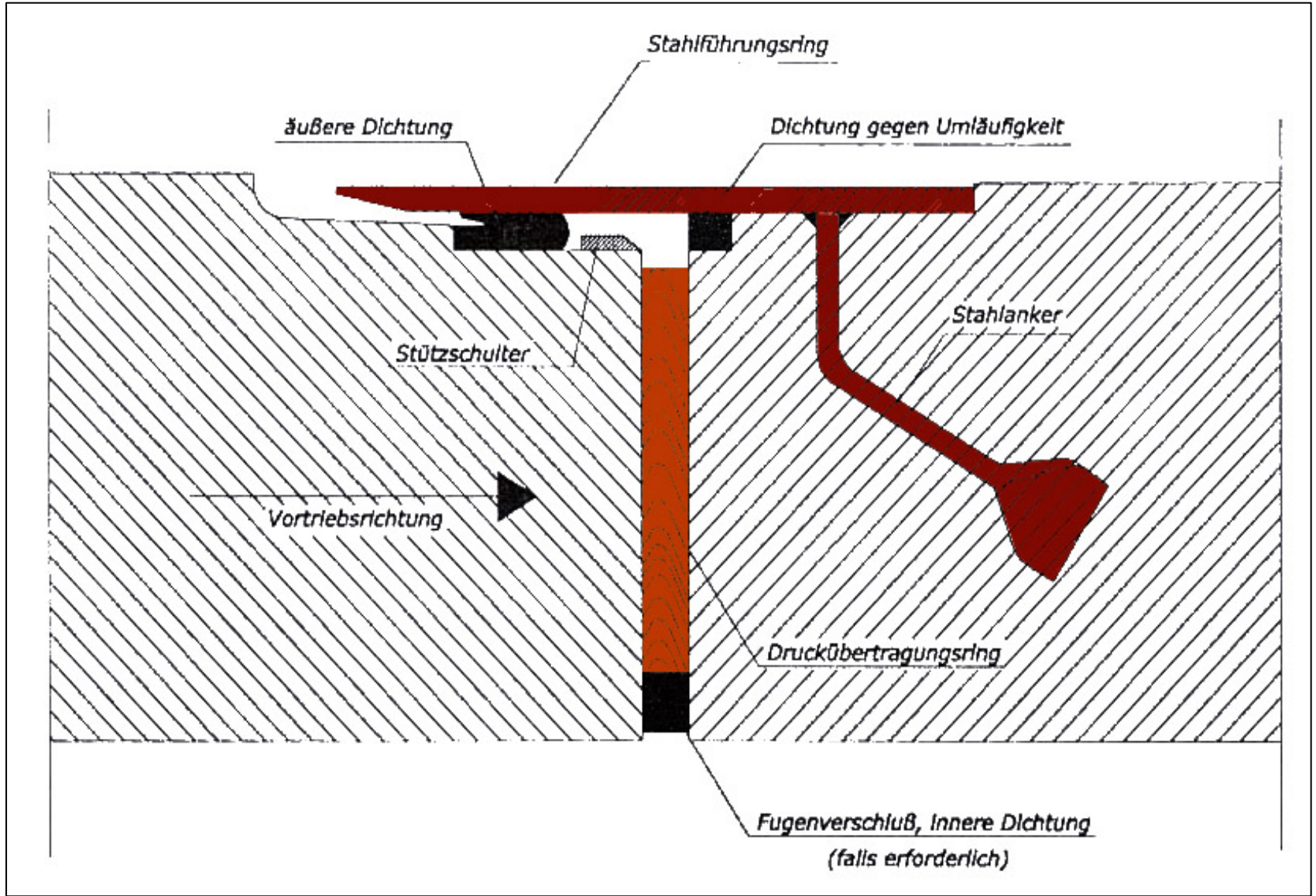

# Druckübertragungsmittel - Werkstoffe

Spannung - Gesamtverformung jeweils nach dem 1. Und 20. Zyklus

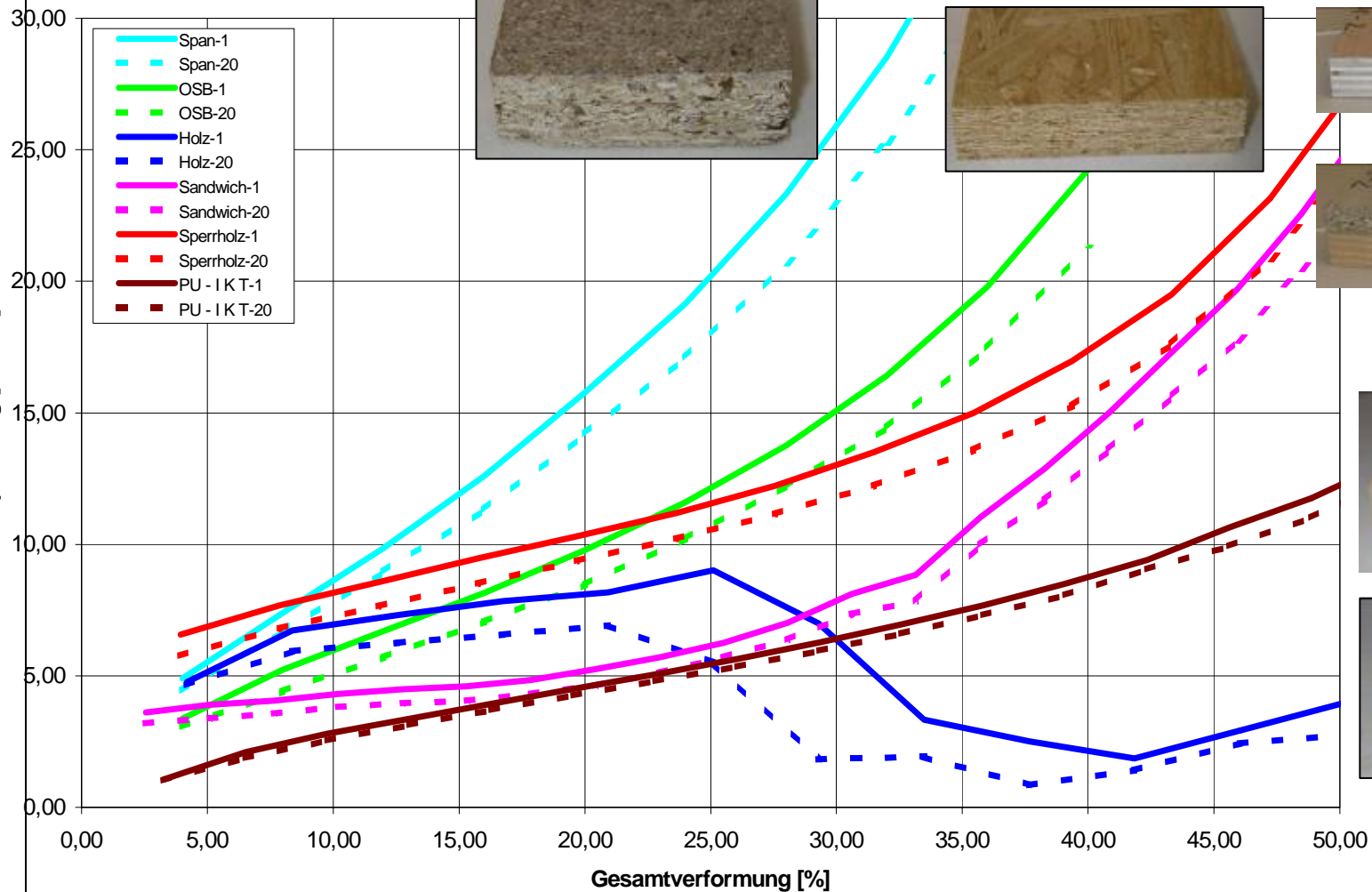

- Span-1
- Span-20
- OSB-1
- OSB-20
- Holz-1
- Holz-20
- Sandwich-1
- Sandwich-20
- Sperrholz-1
- Sperrholz-20
- PU - IKT-1
- PU - IKT-20

# Druckübertragungsmittel - Imperfektionen





# Druckübertragungsmittel - Baustelleneinsatz



# Ziel: Funktionsfähige Rohrleitung

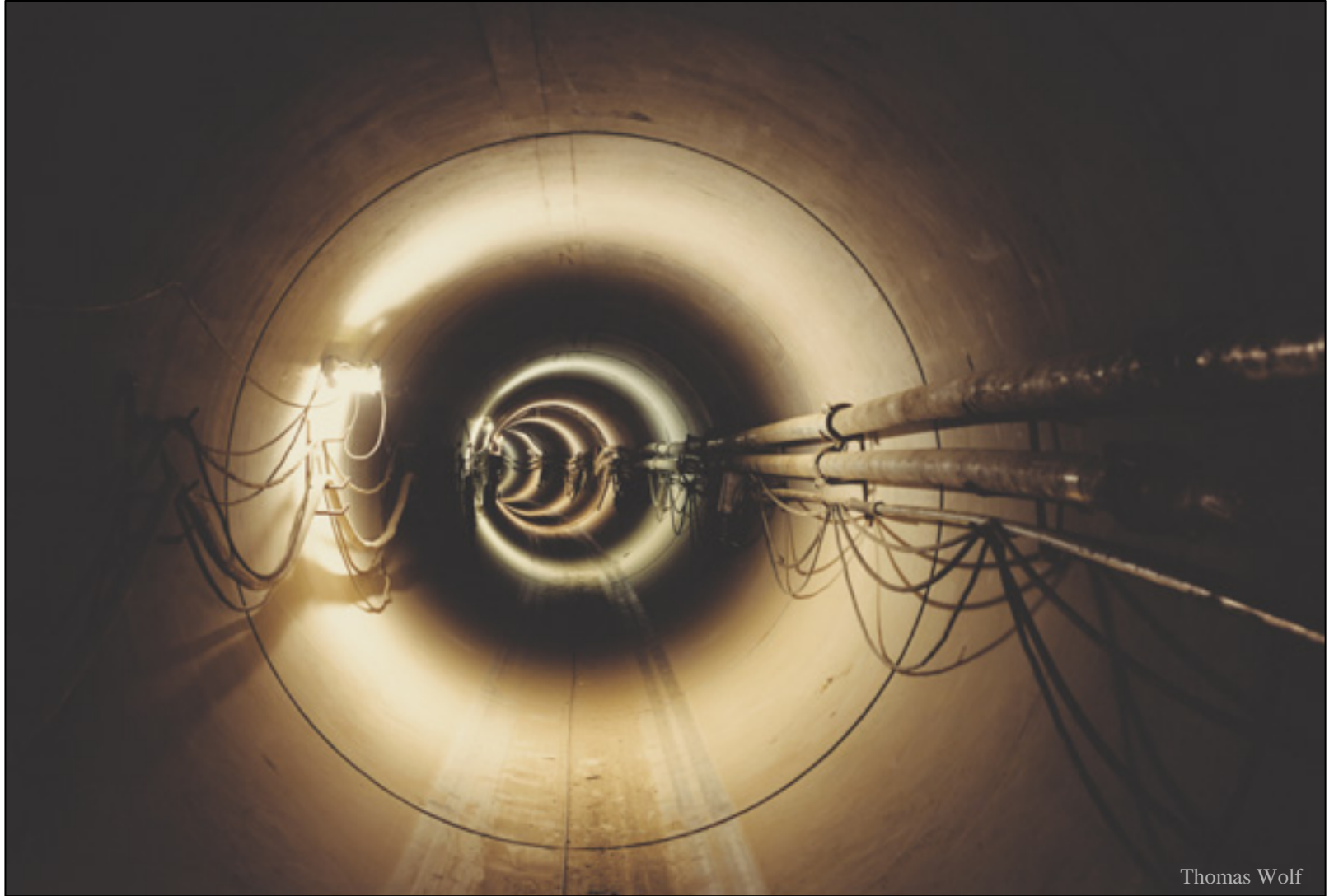

# Aufgabenstellung

## Bemessungsansätze

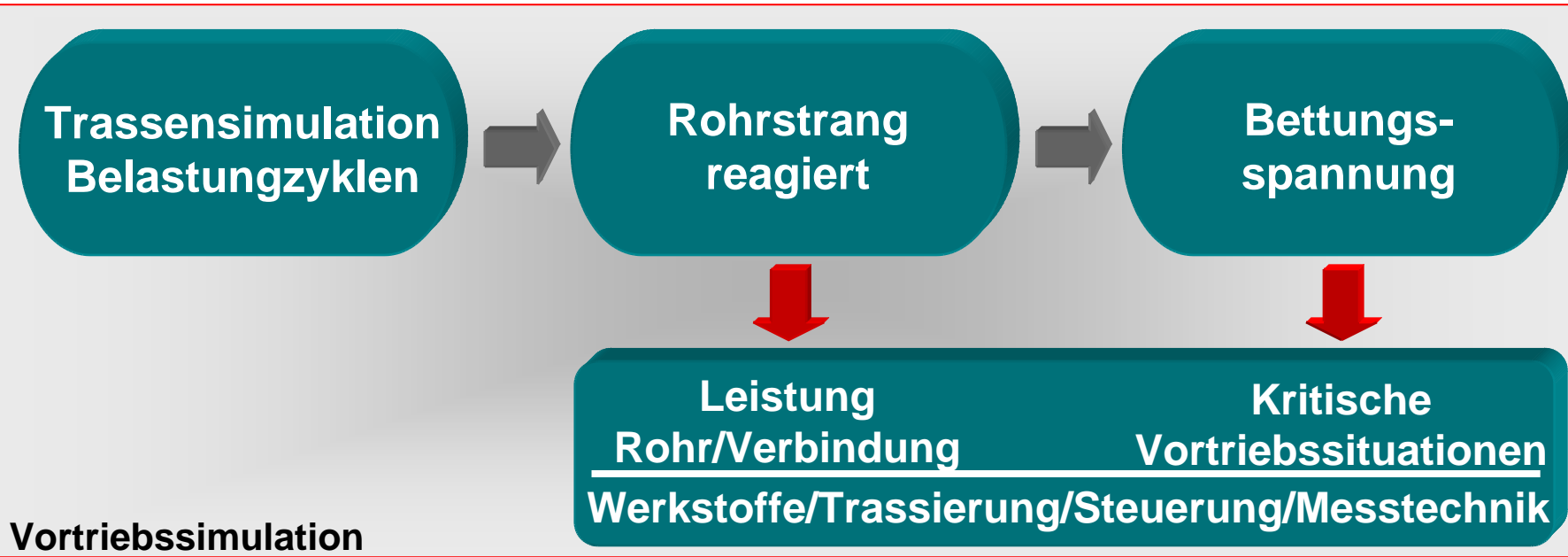
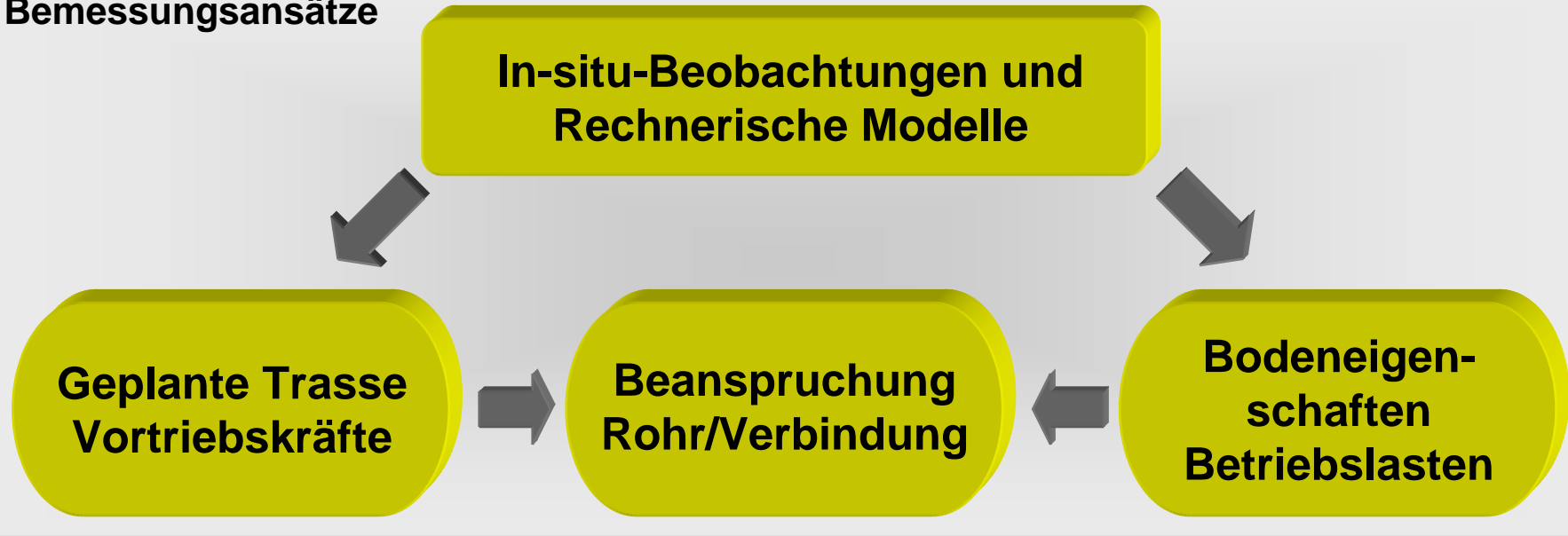



1. Hintergrund

**2. Vortriebssimulator**

3. Auswertung

4. Ausblick

# IKT- Großversuchsstand

IKT - Institut für Unterirdische Infrastruktur

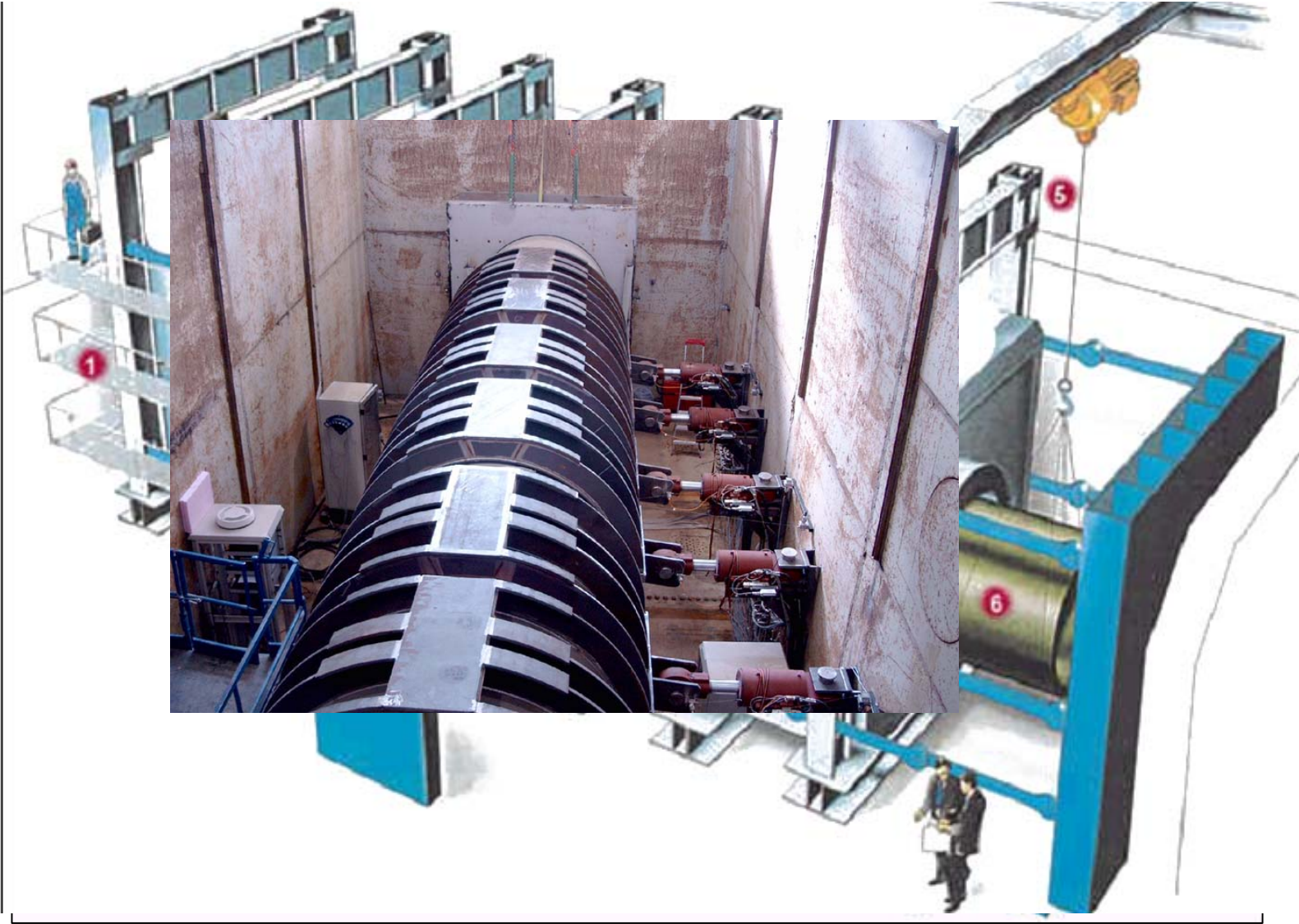

Simulation ohne Boden

## 8 Stahlringe zur Rohrführung



## 5 Vortriebsrohre DN 1600



## **Vorpresseinheit (4 x 2.000 kN)**





## 8 Horizontalzylinder á 1.000 kN



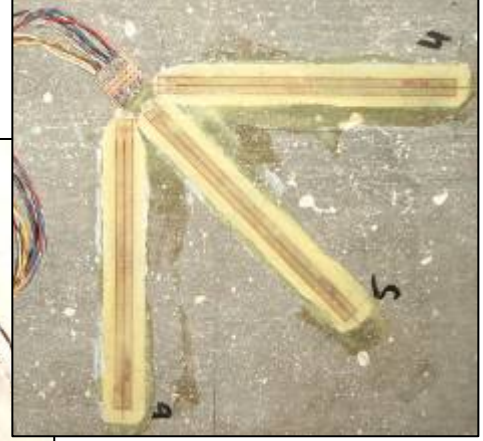
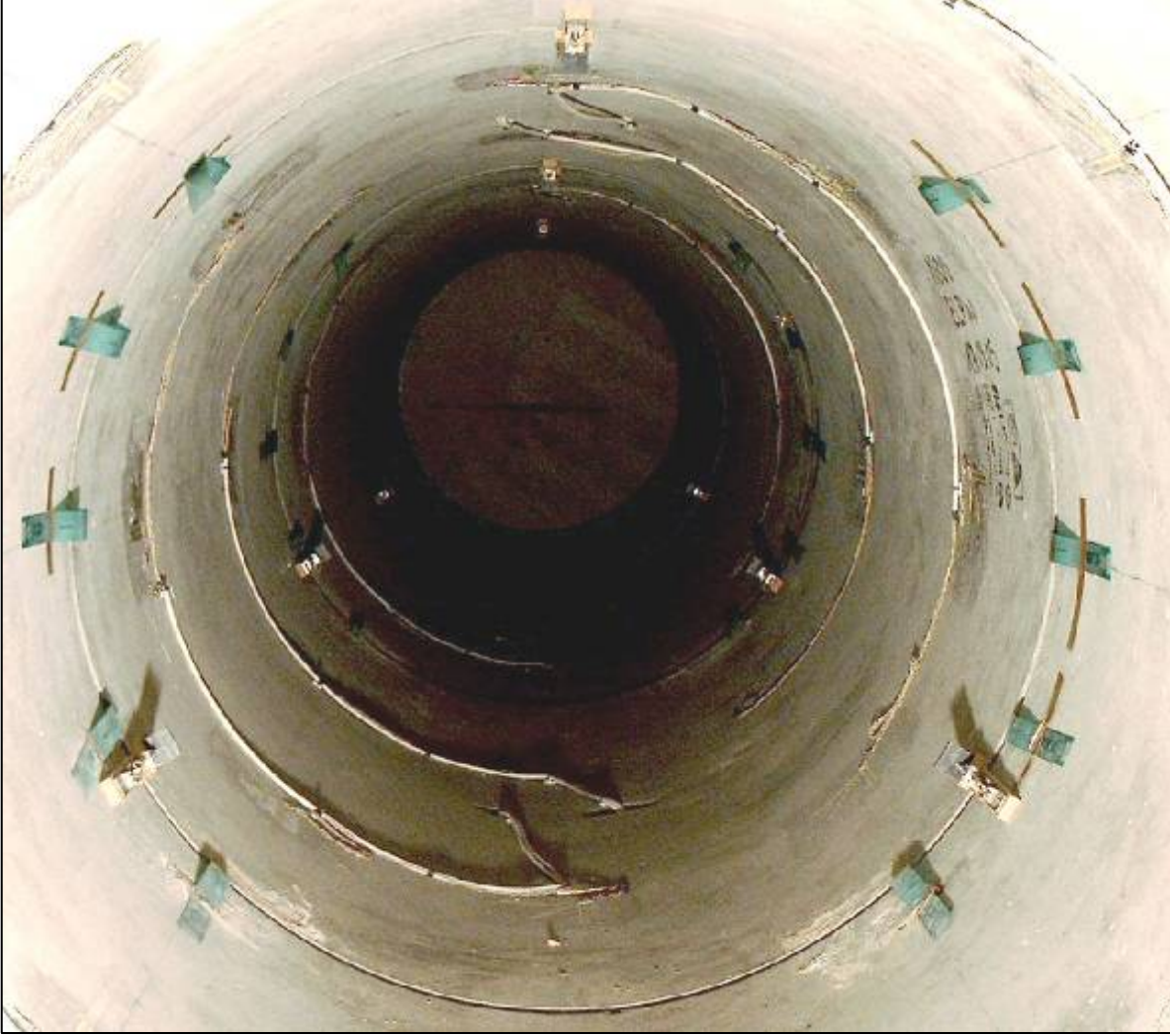

**An die Rohraußenkontur angepasste Wölbung,  
Bauhöhe 2 cm, belastbar bis 5 bar**

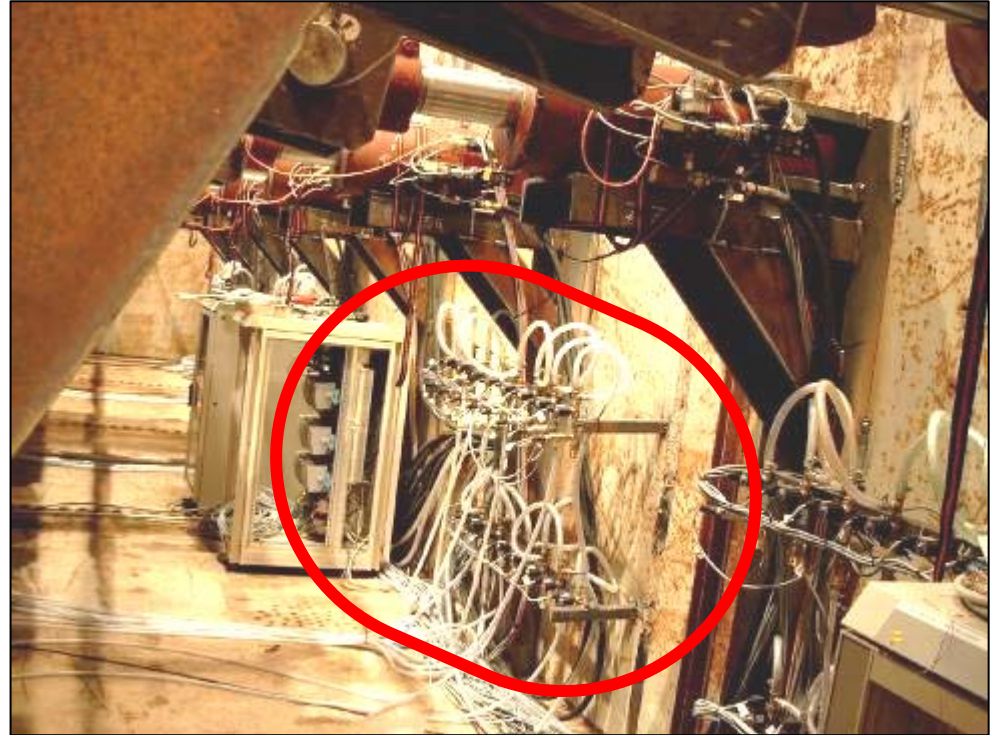
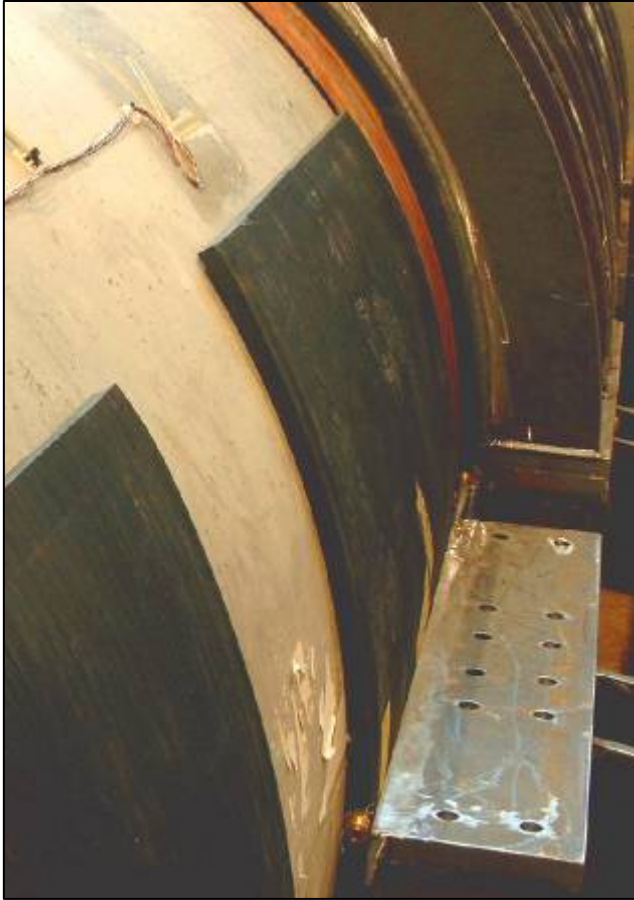

**64 elektrische Regelventile,  
32 Drucksensoren**



# Zusammenstellung Beispieltrasse

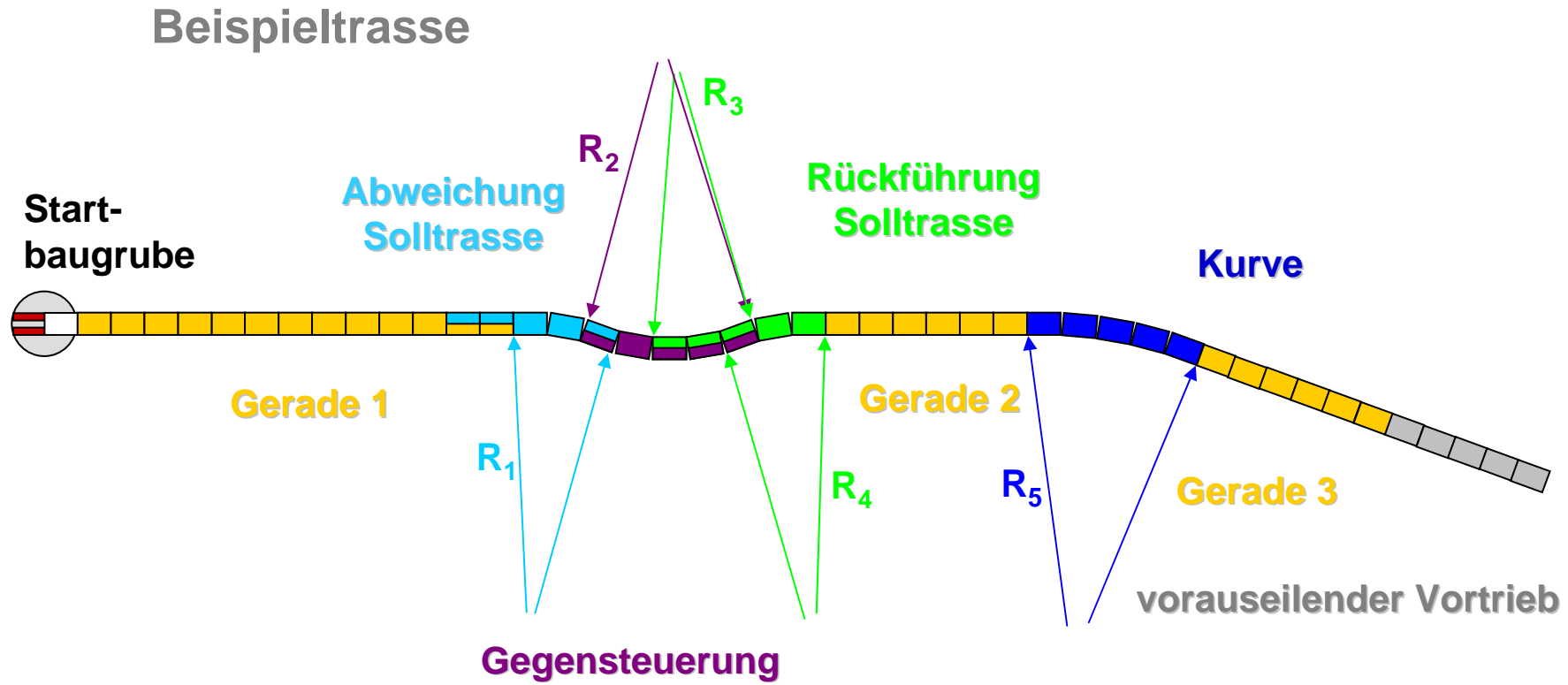

# Trassenabschnitt Nr. 1: Gerade

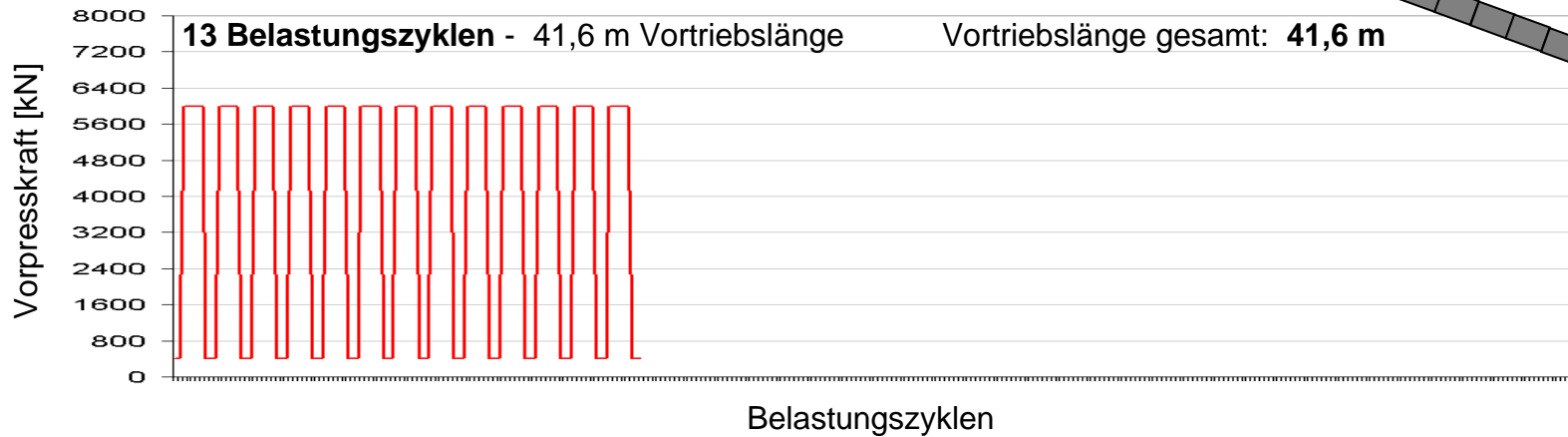
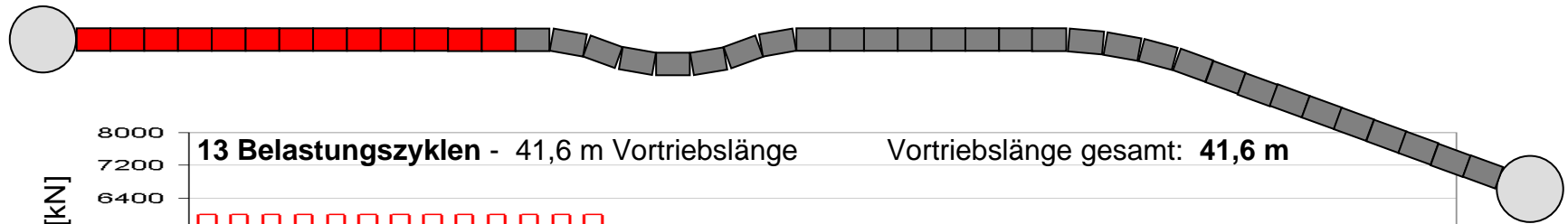
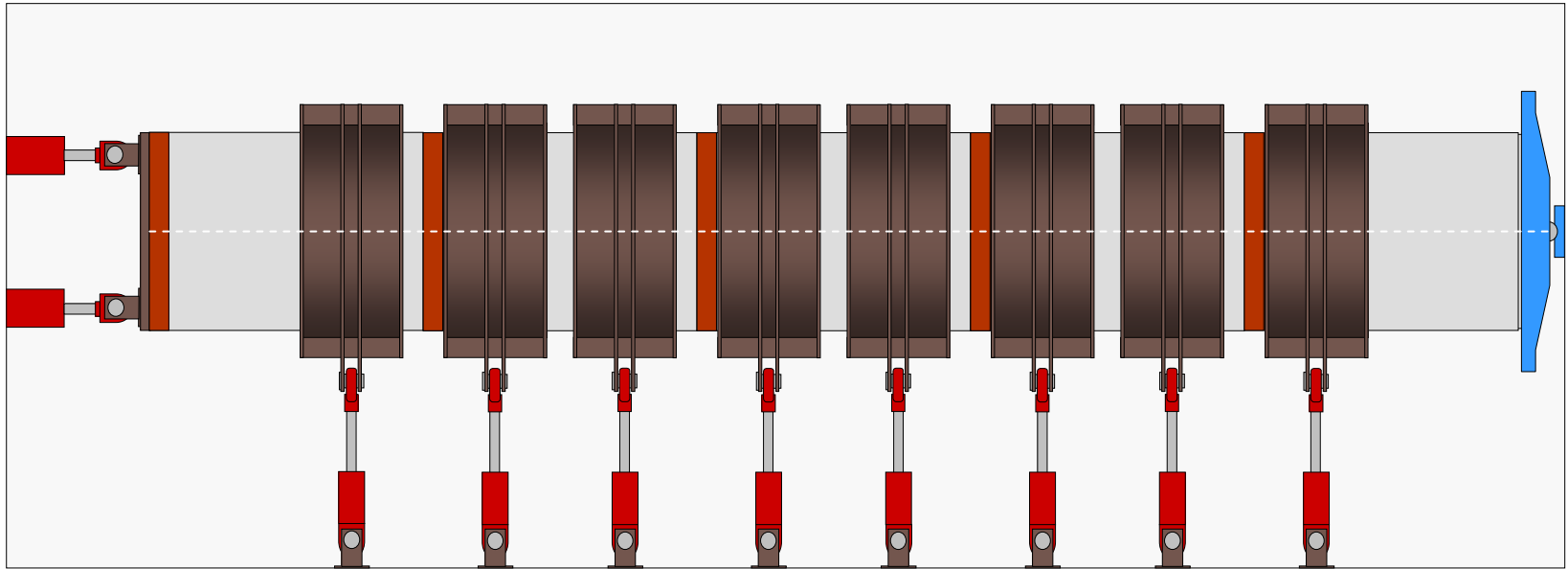

# Trassenabschnitt Nr. 2: Abweichung Solltrasse

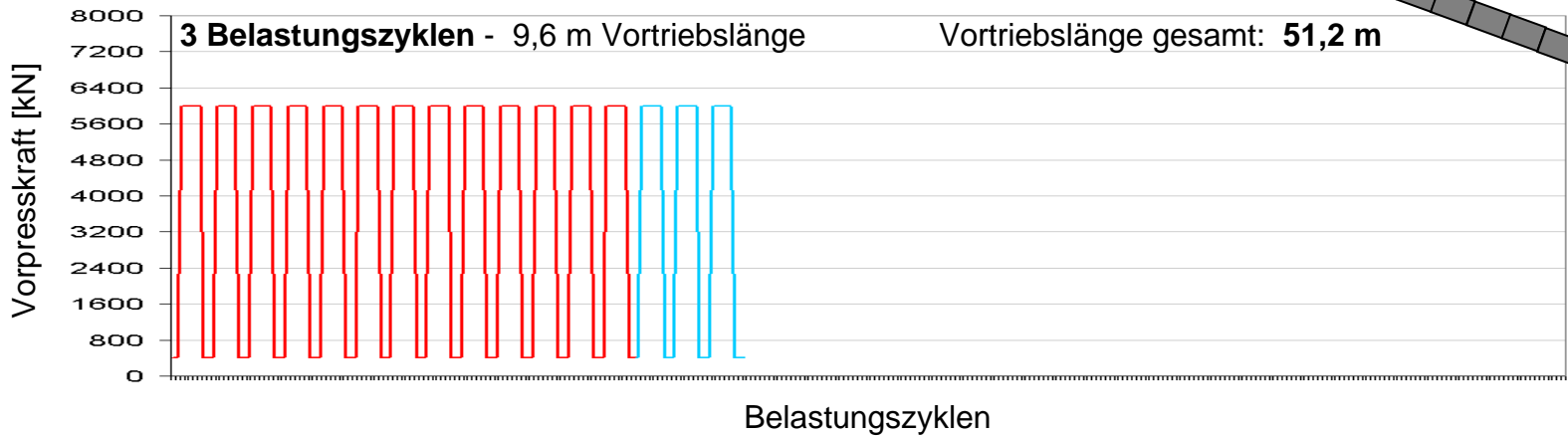
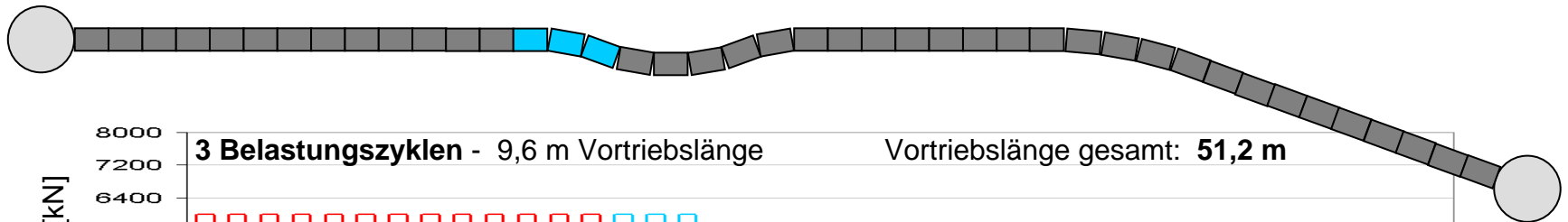
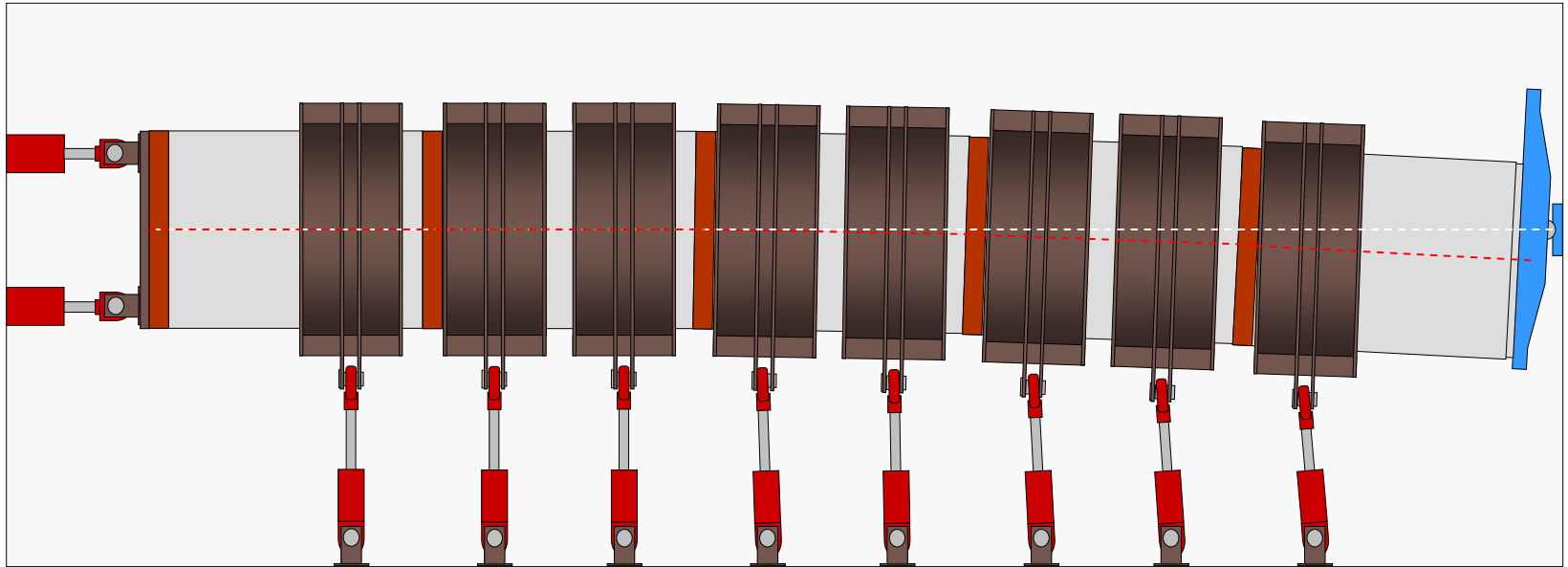

# Trassenabschnitt Nr. 3: Gegensteuerung

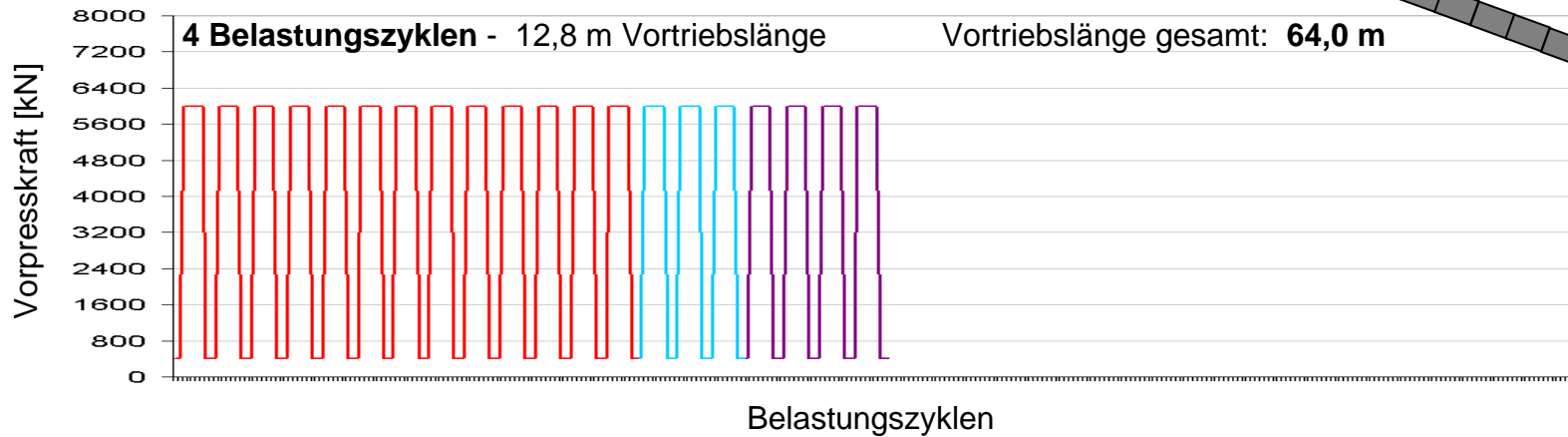
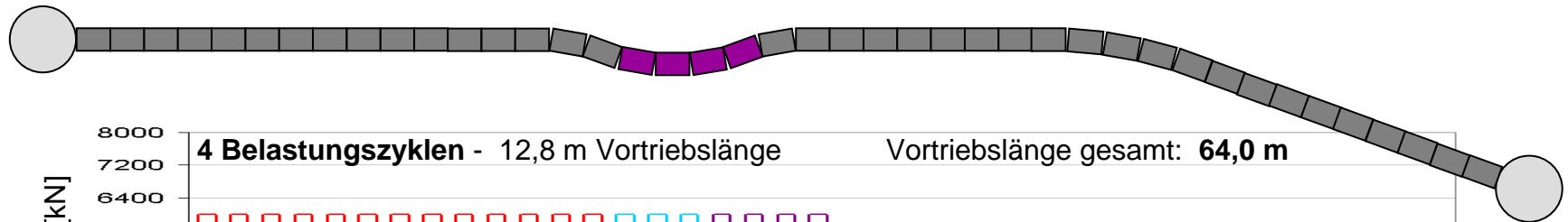
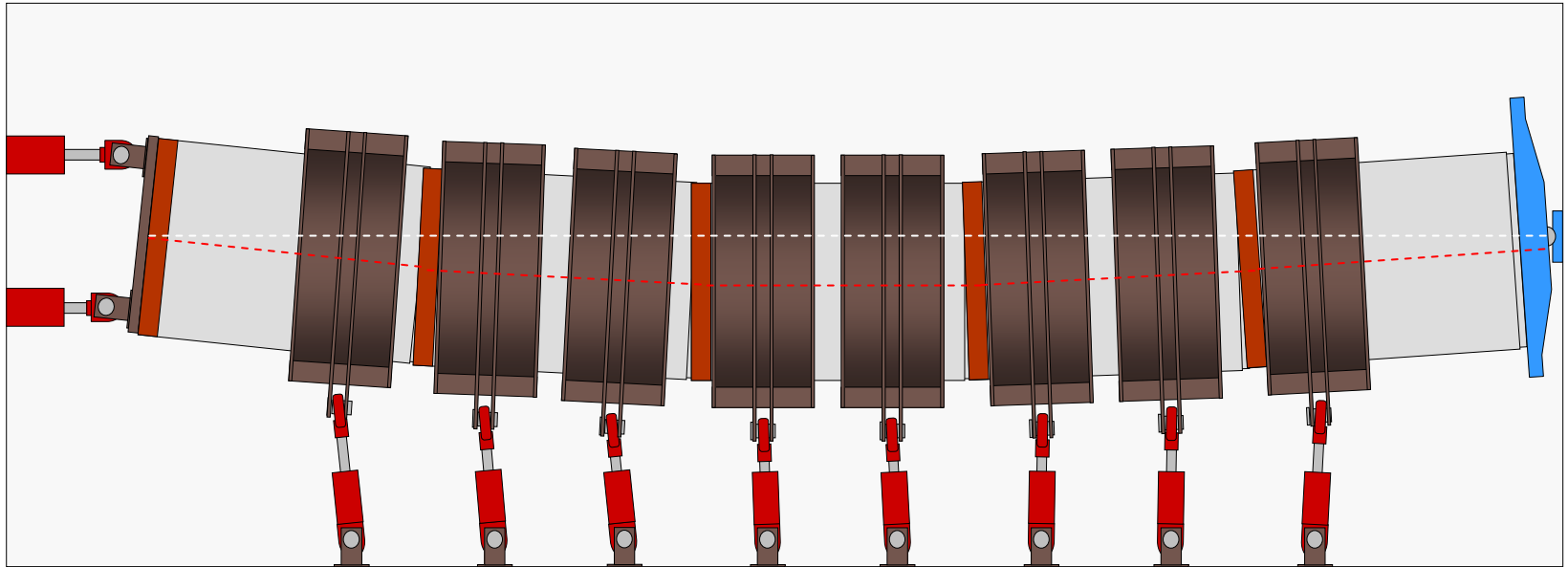



# Trassenabschnitt Nr. 4: Rückführung Solltrasse

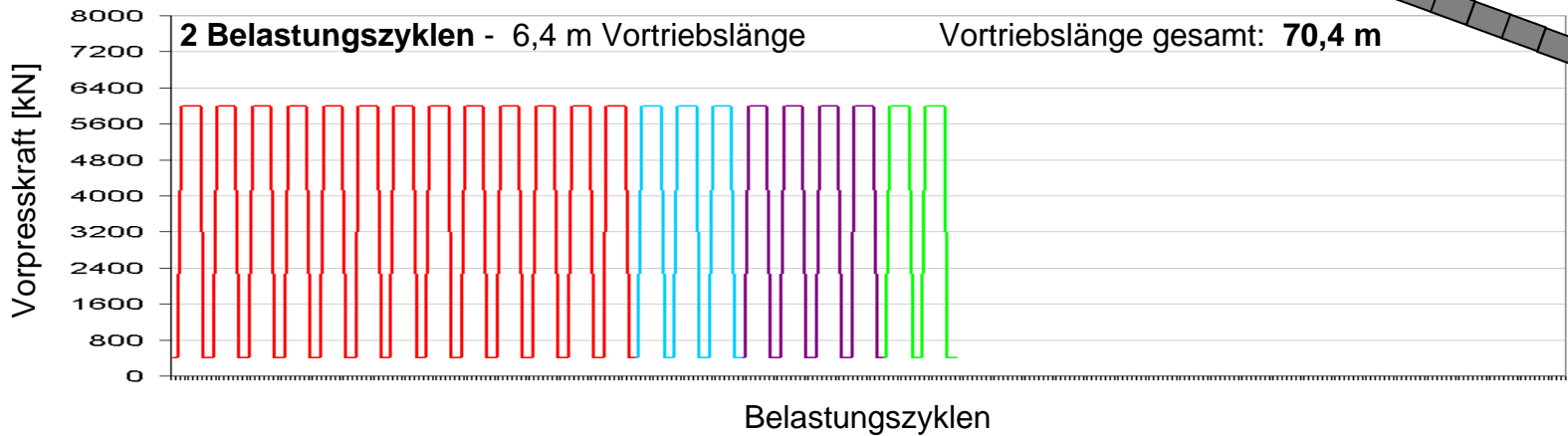
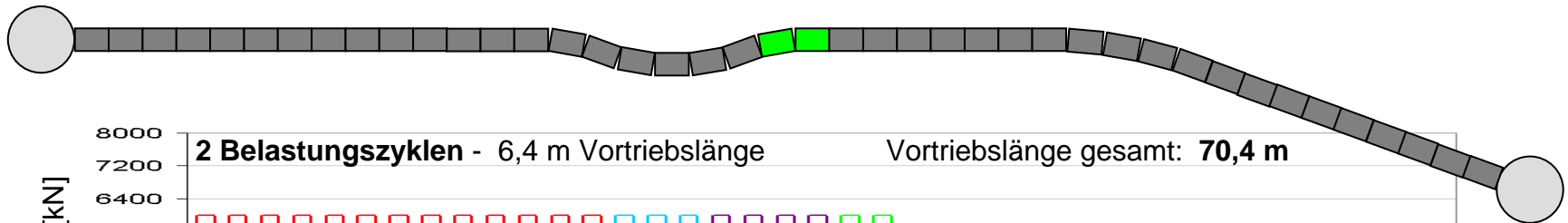
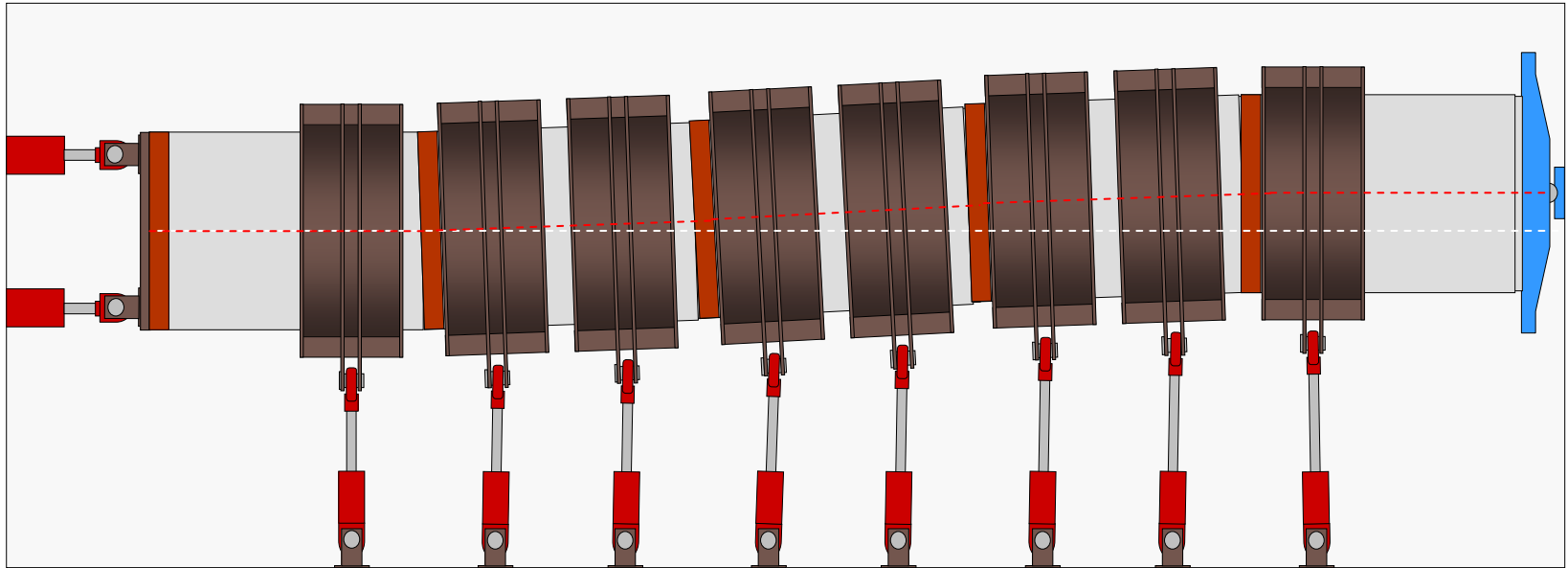

# Trassenabschnitt Nr. 5: Gerade

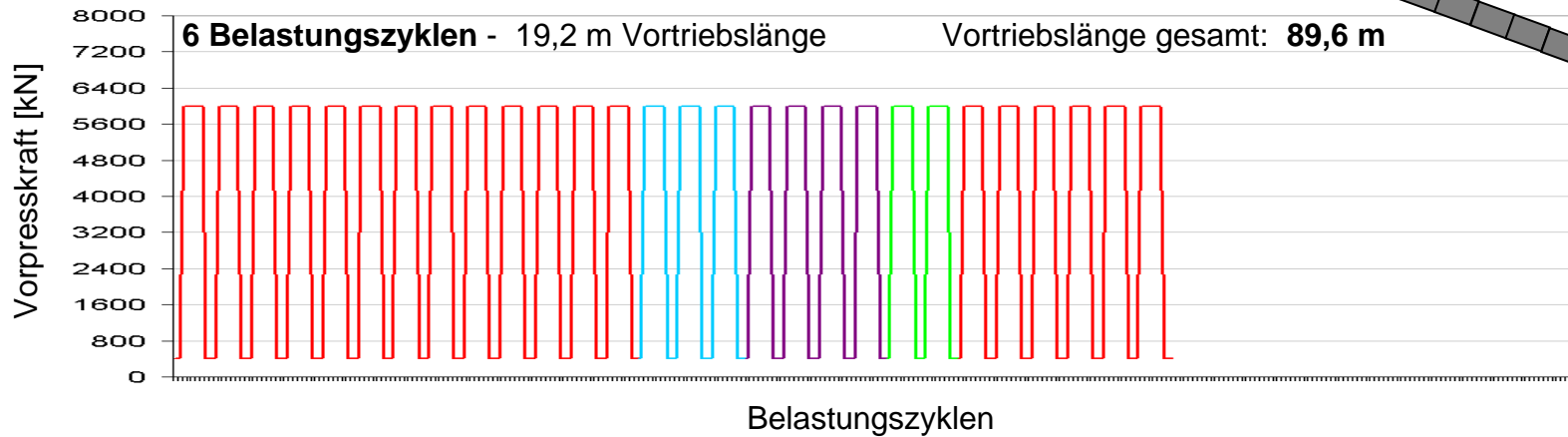
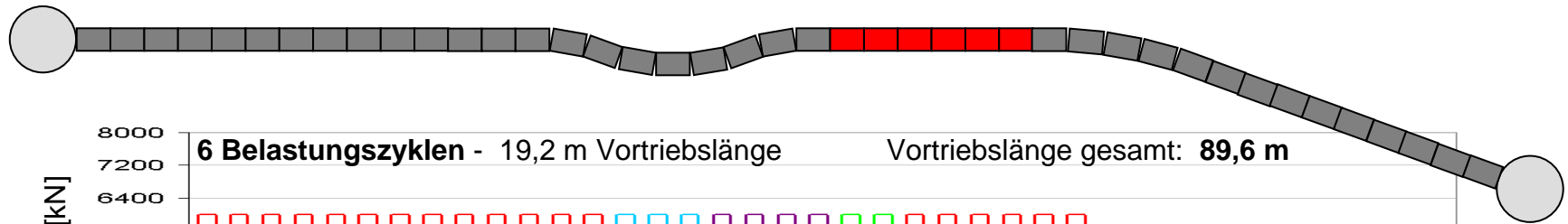
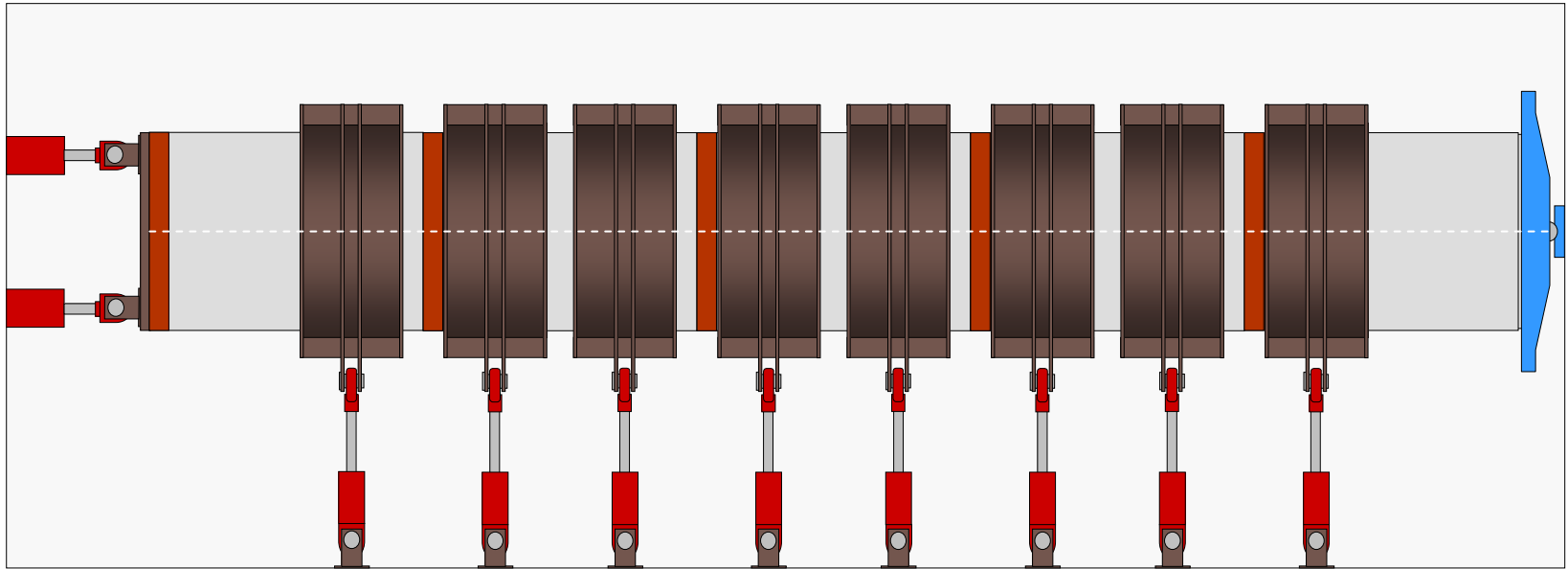

# Trassenabschnitt Nr. 6: Kurve

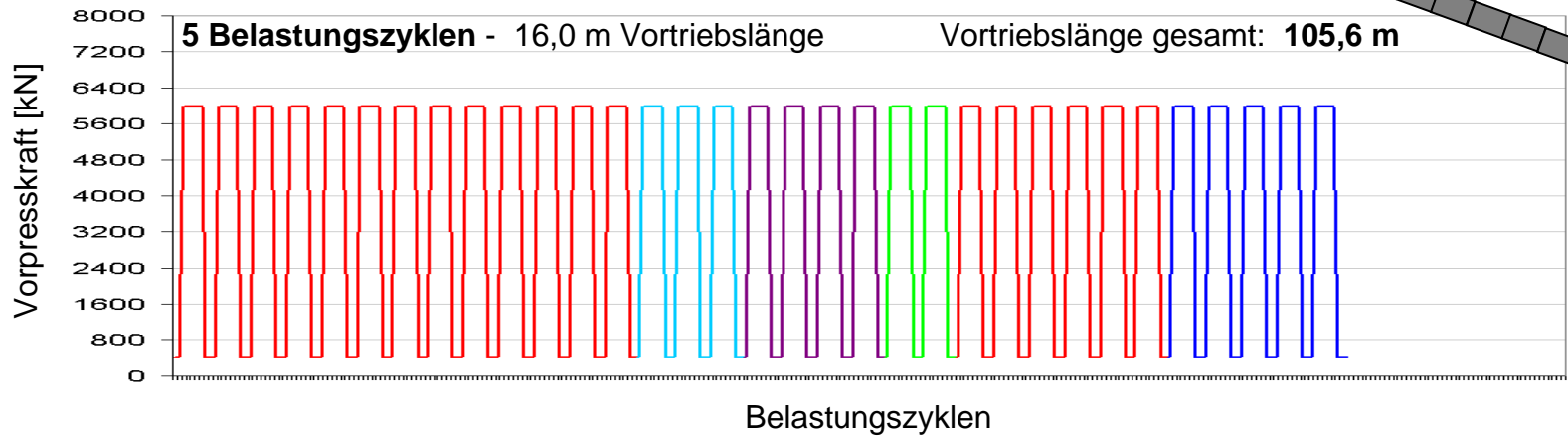
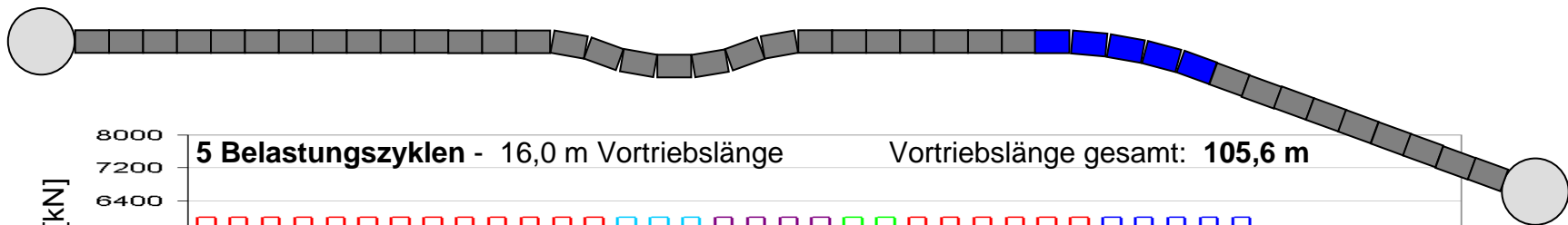
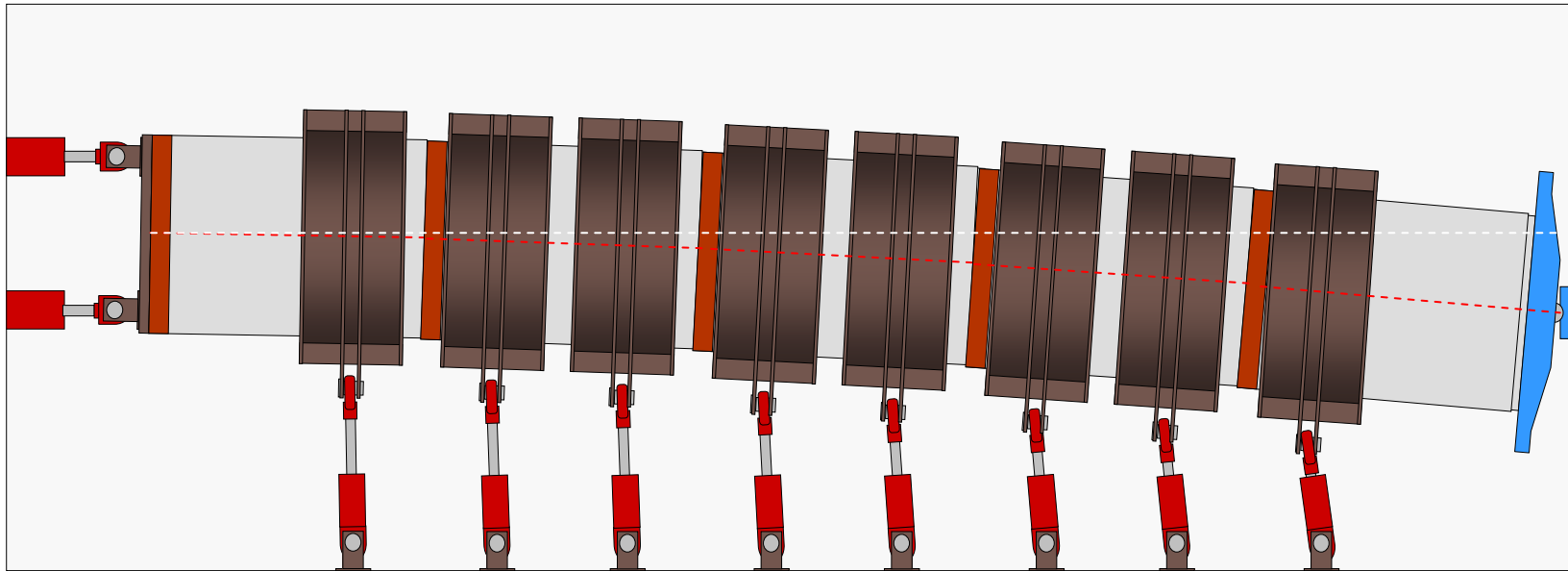

# Trassenabschnitt Nr. 7: Gerade

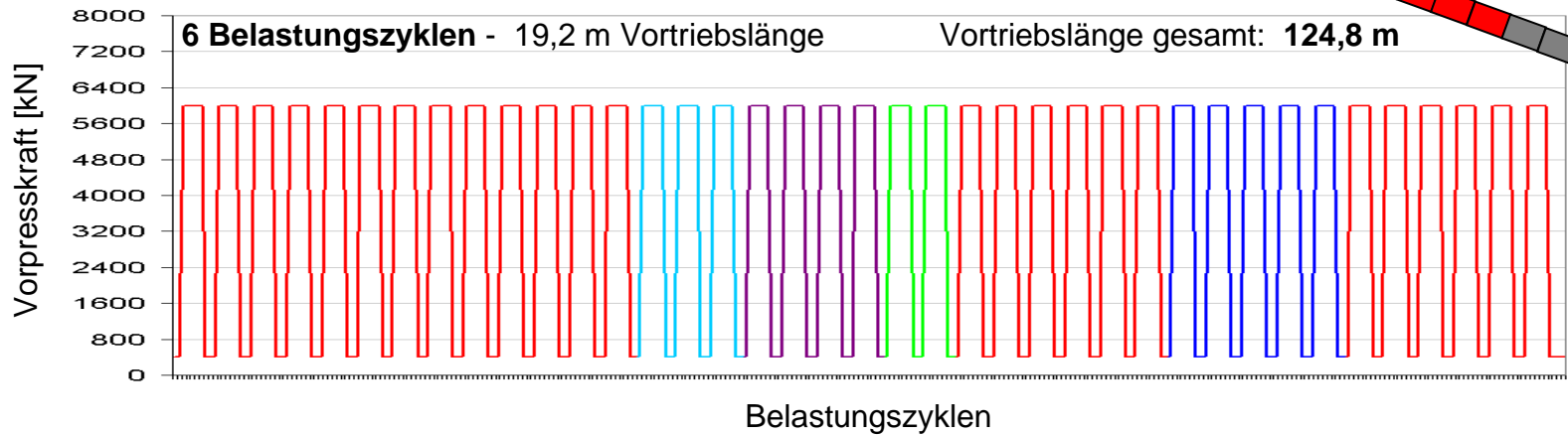
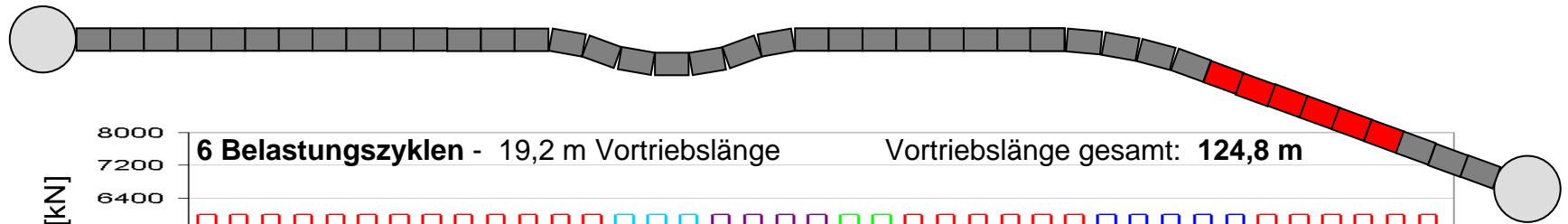
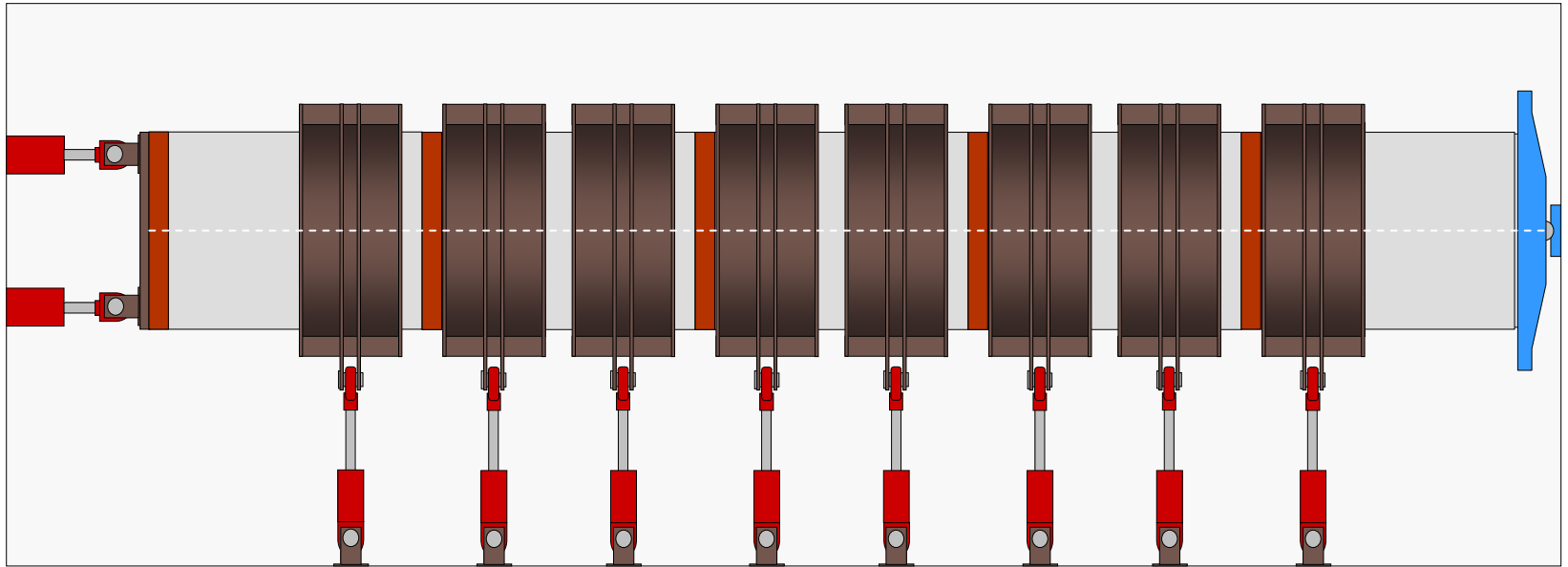

## Mantel-Segment Druckkissen

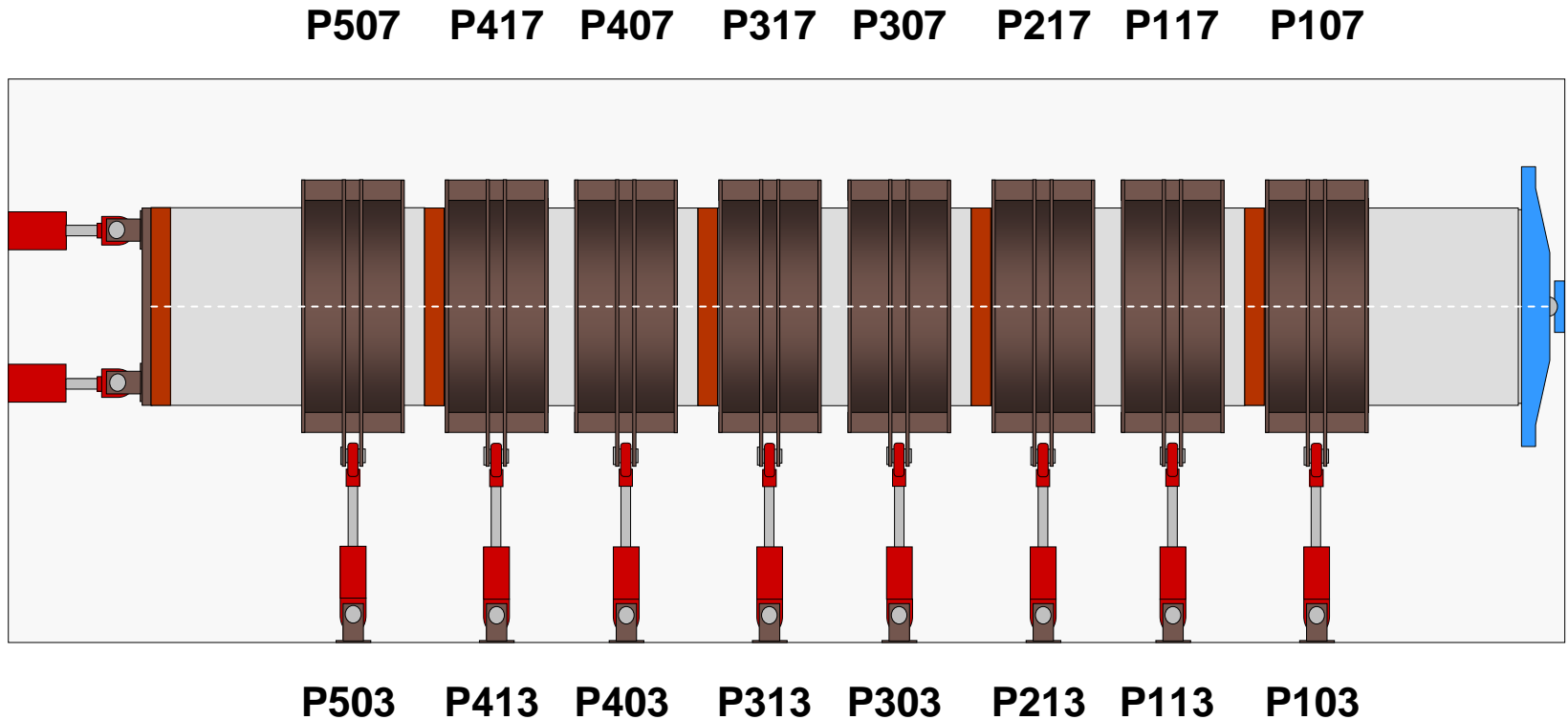









# Kissendruckänderung im Rohrkämpfer

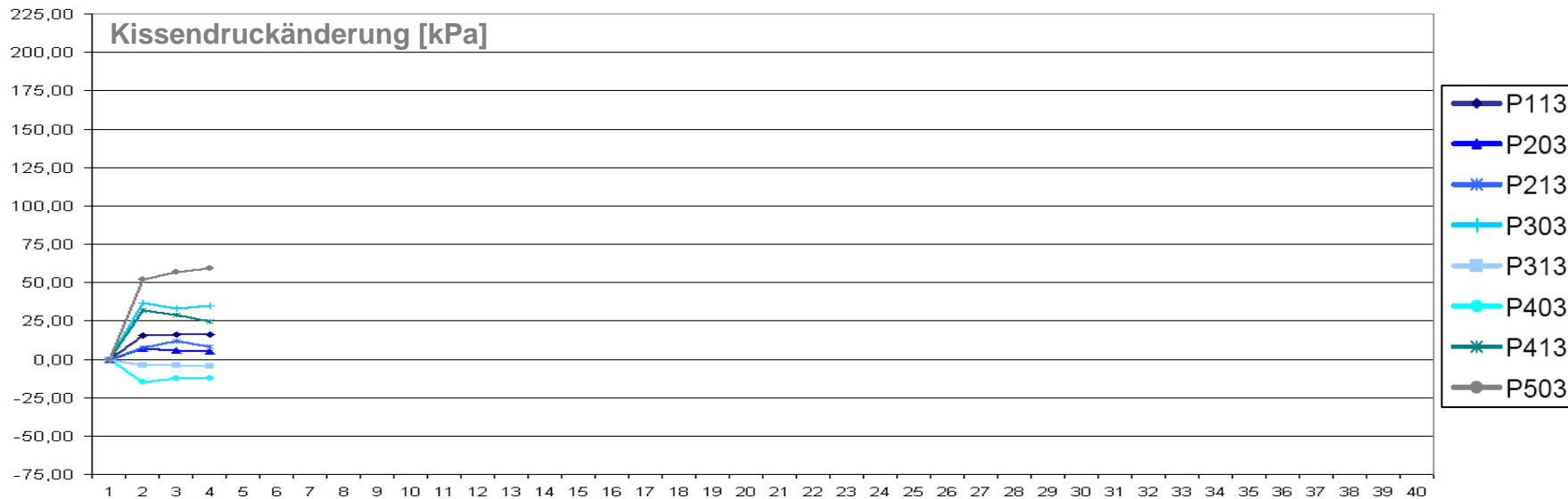
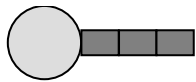
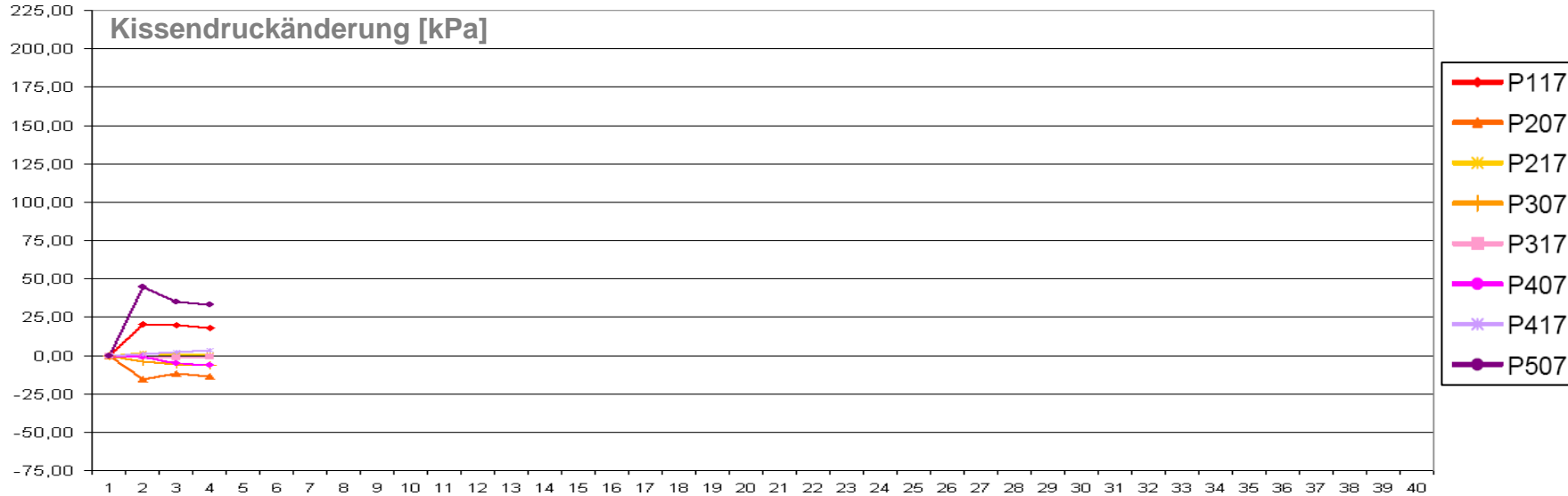

# Kissendruckänderung im Rohrkämpfer

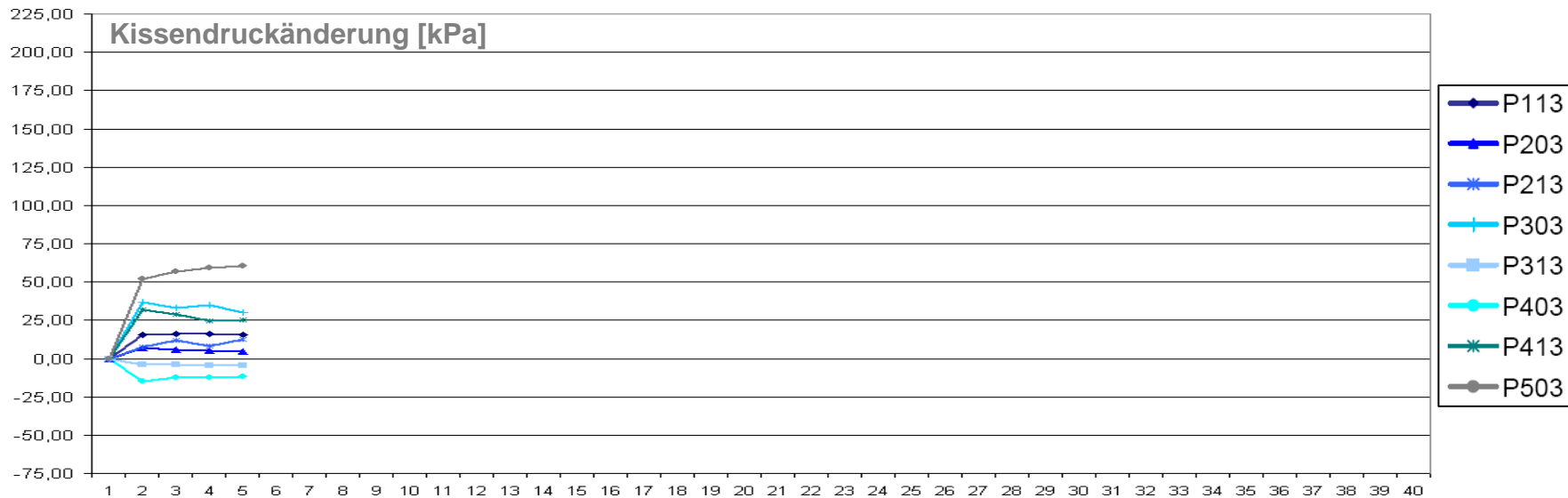
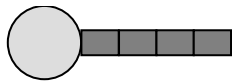
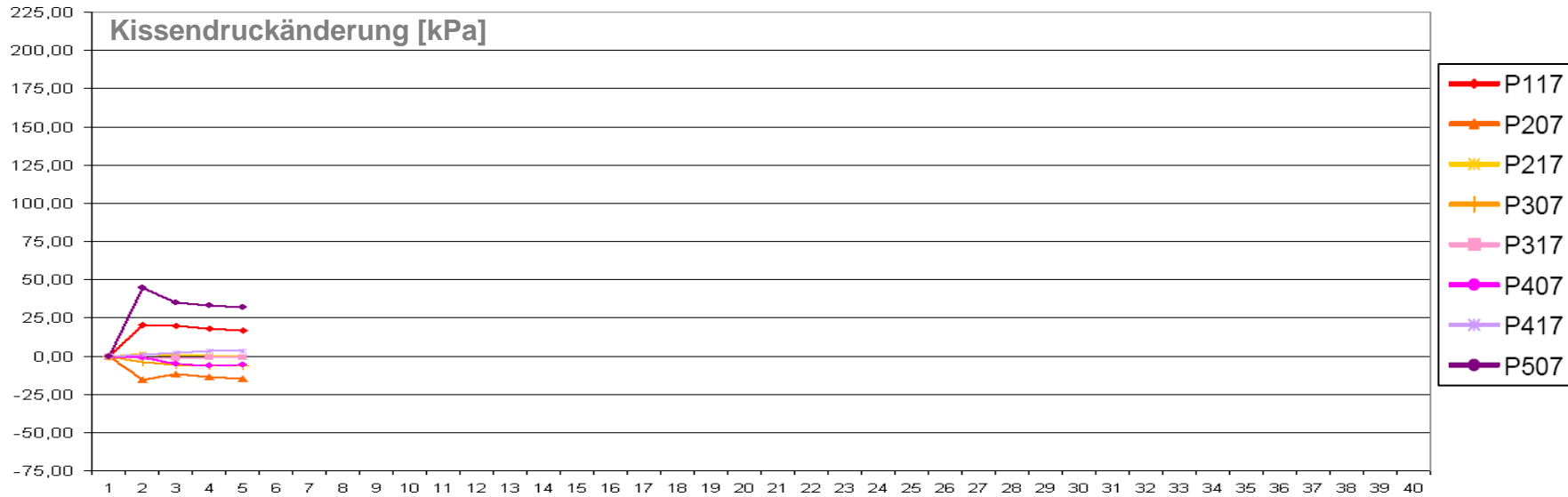

# Kissendruckänderung im Rohrkämpfer

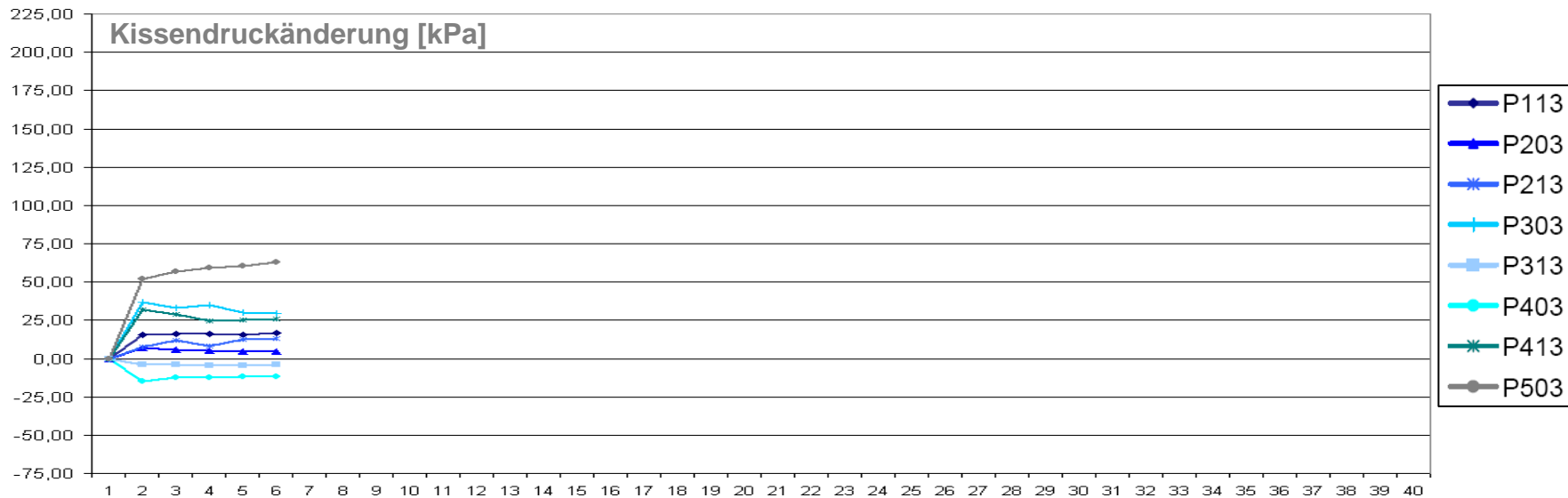
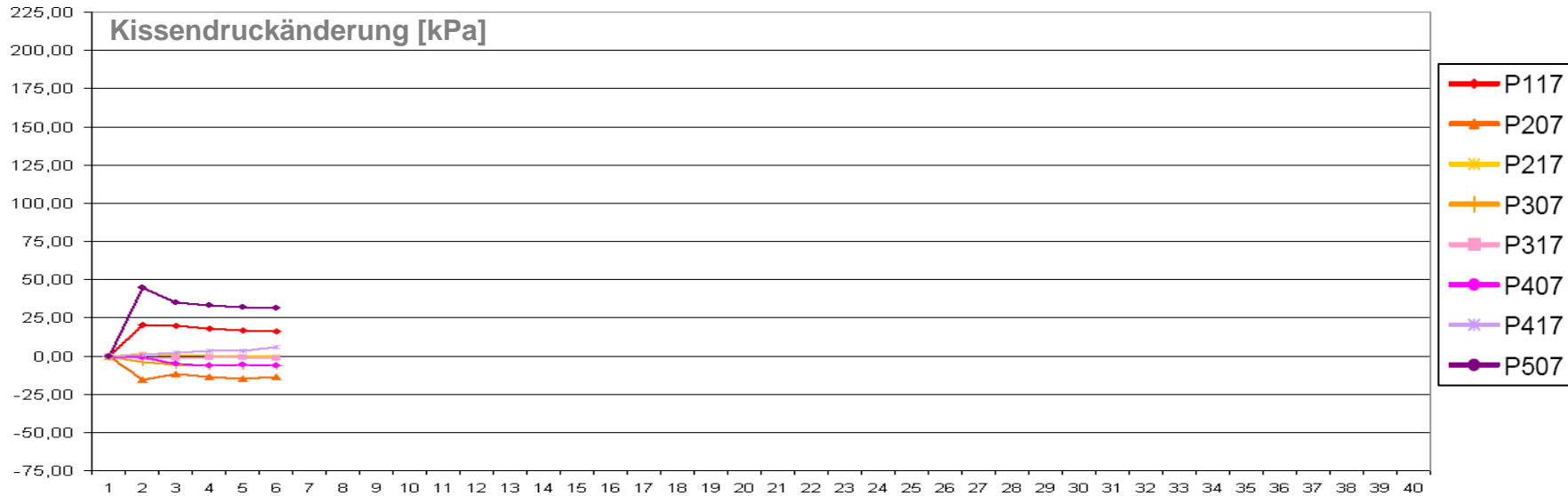

# Kissendruckänderung im Rohrkämpfer

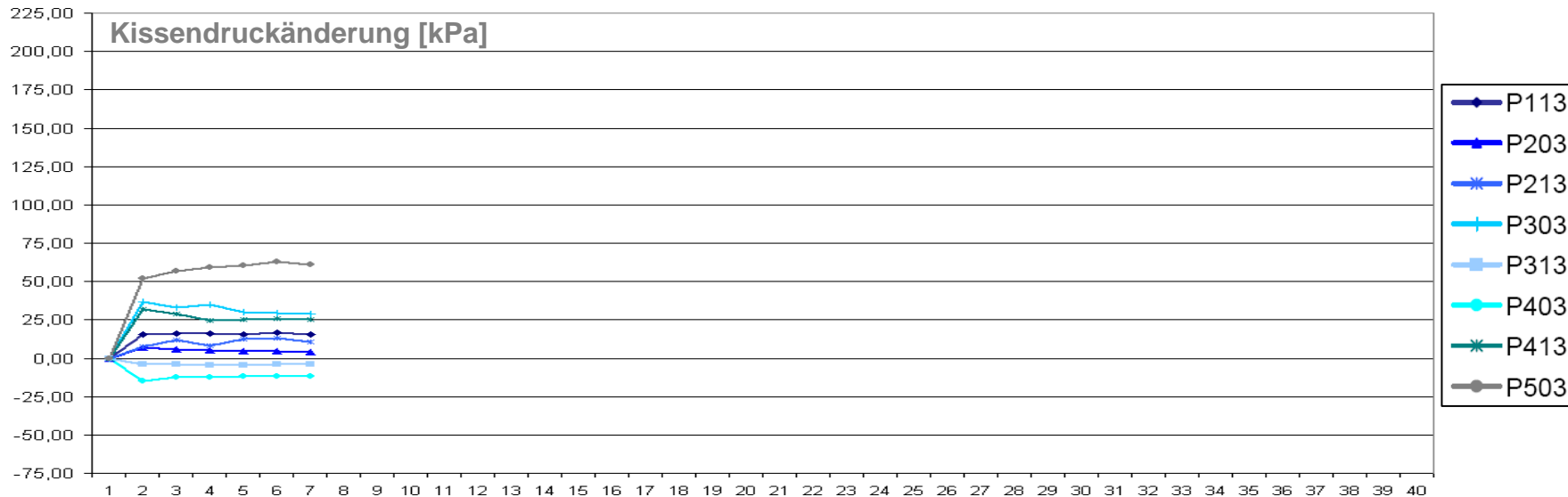
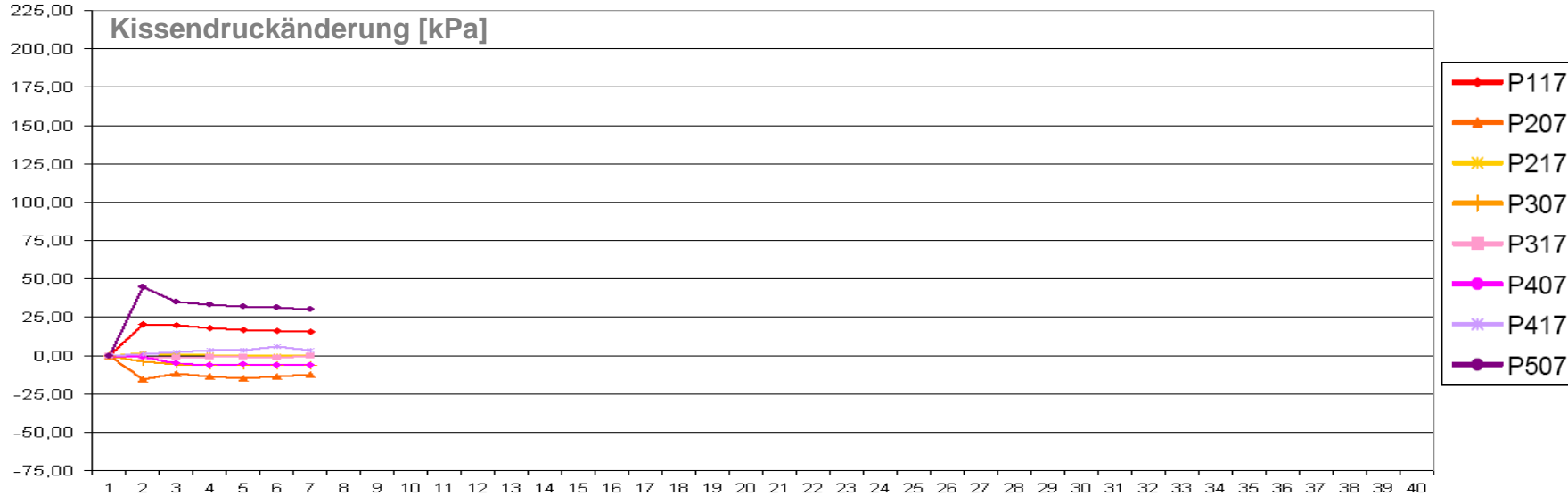

# Kissendruckänderung im Rohrkämpfer

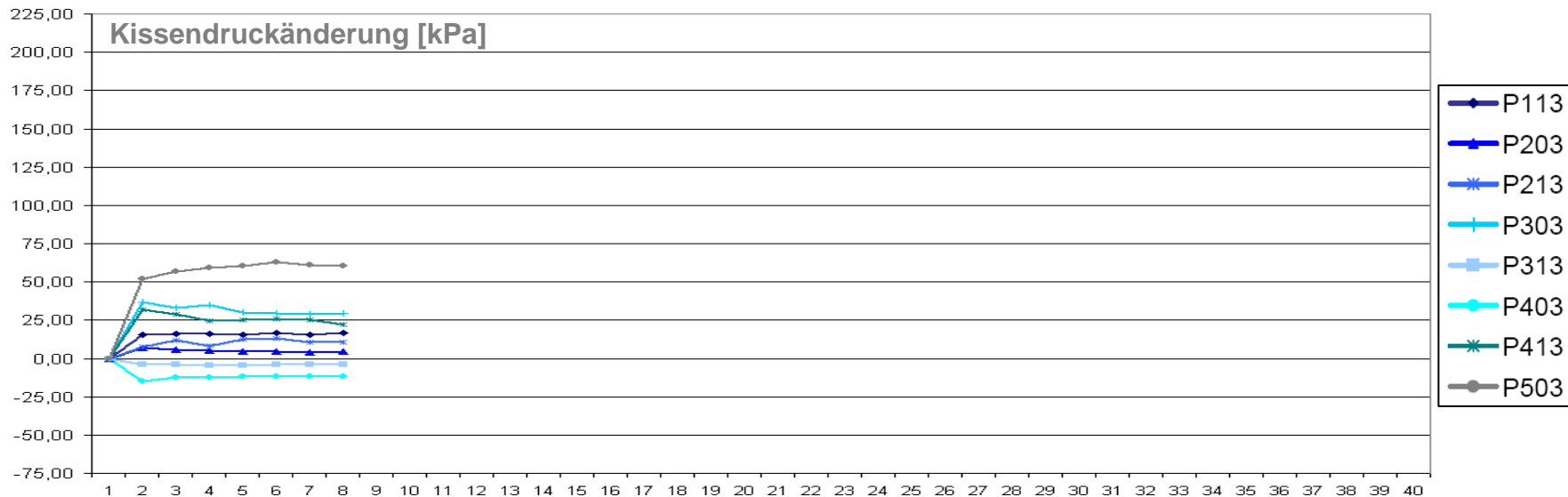
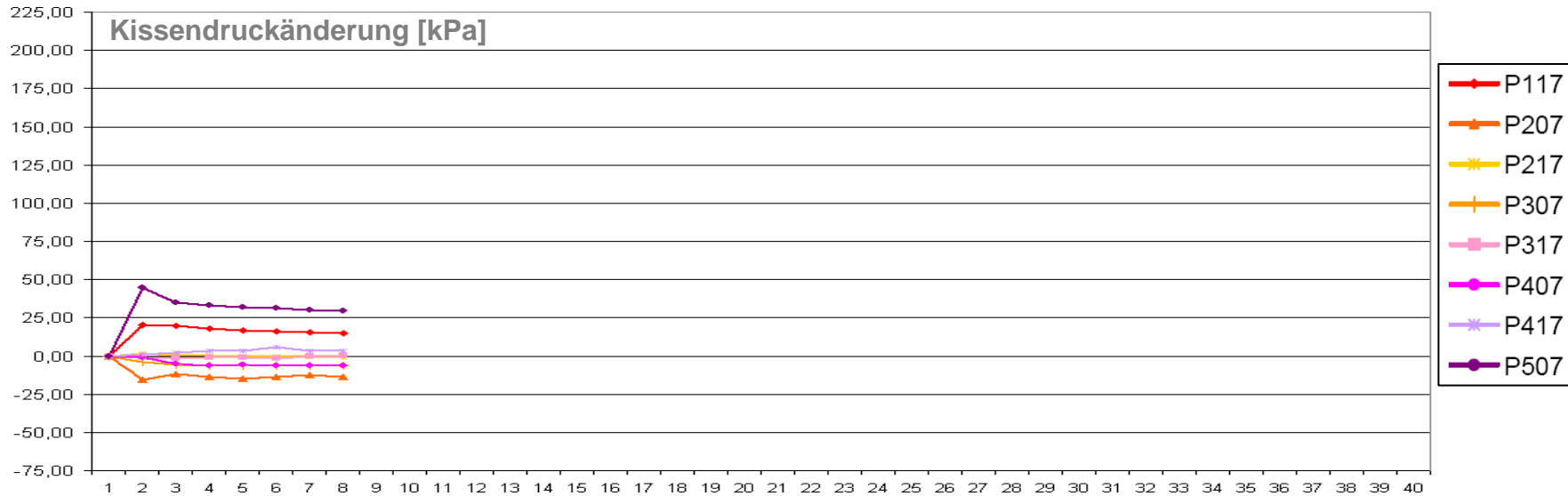

# Kissendruckänderung im Rohrkämpfer

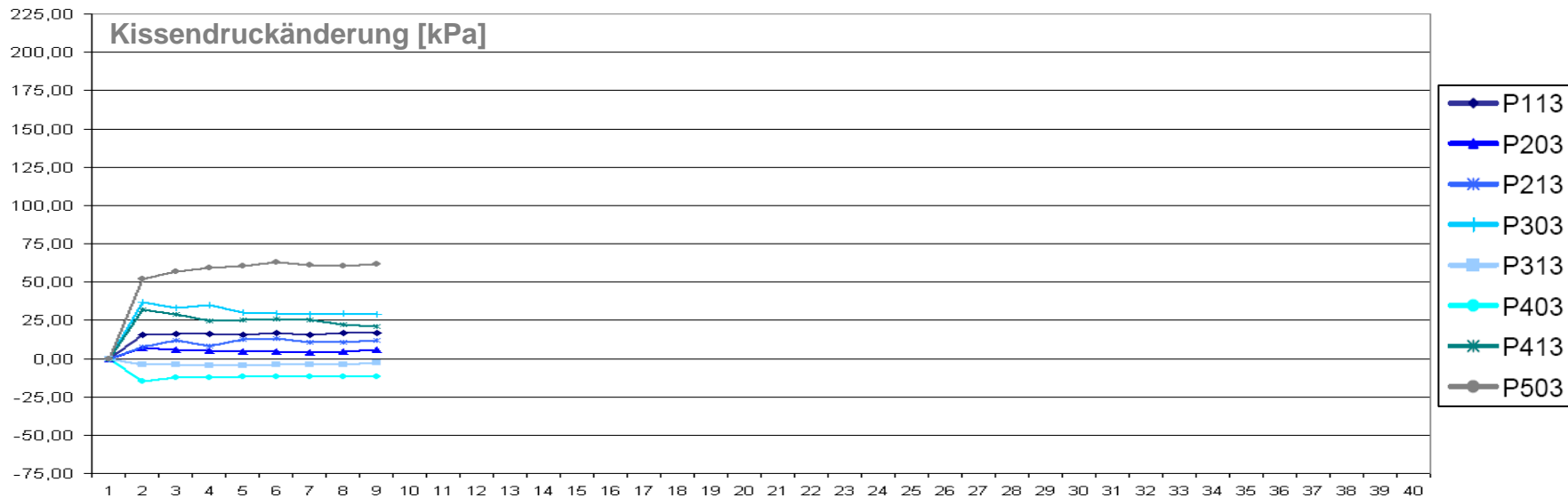
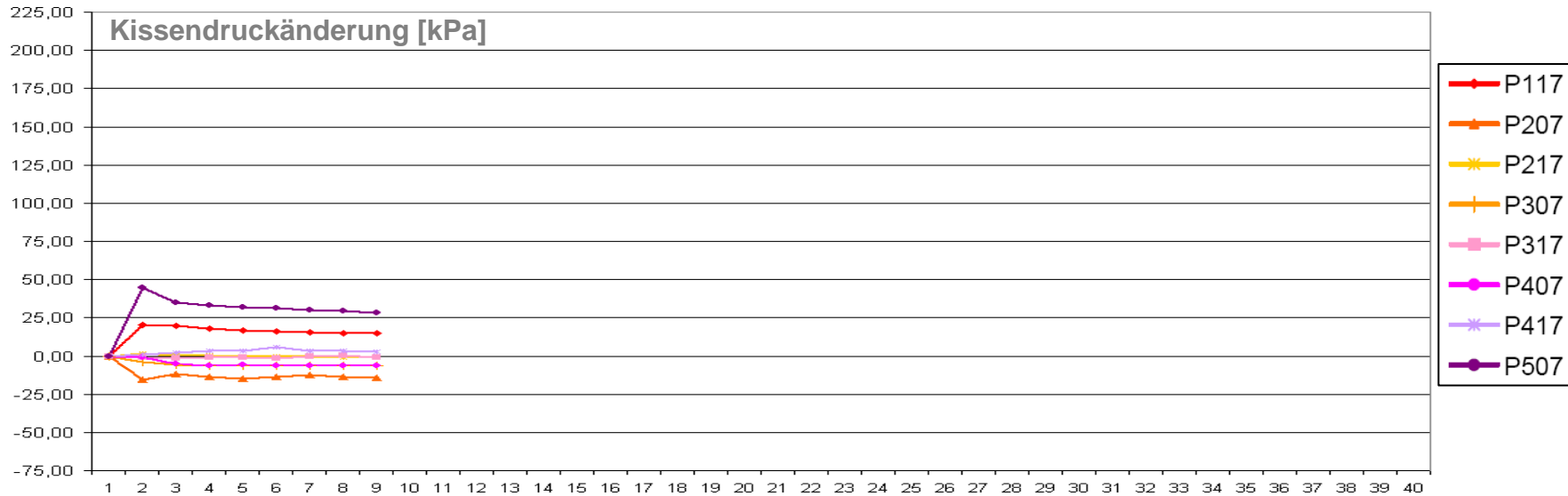

# Kissendruckänderung im Rohrkämpfer

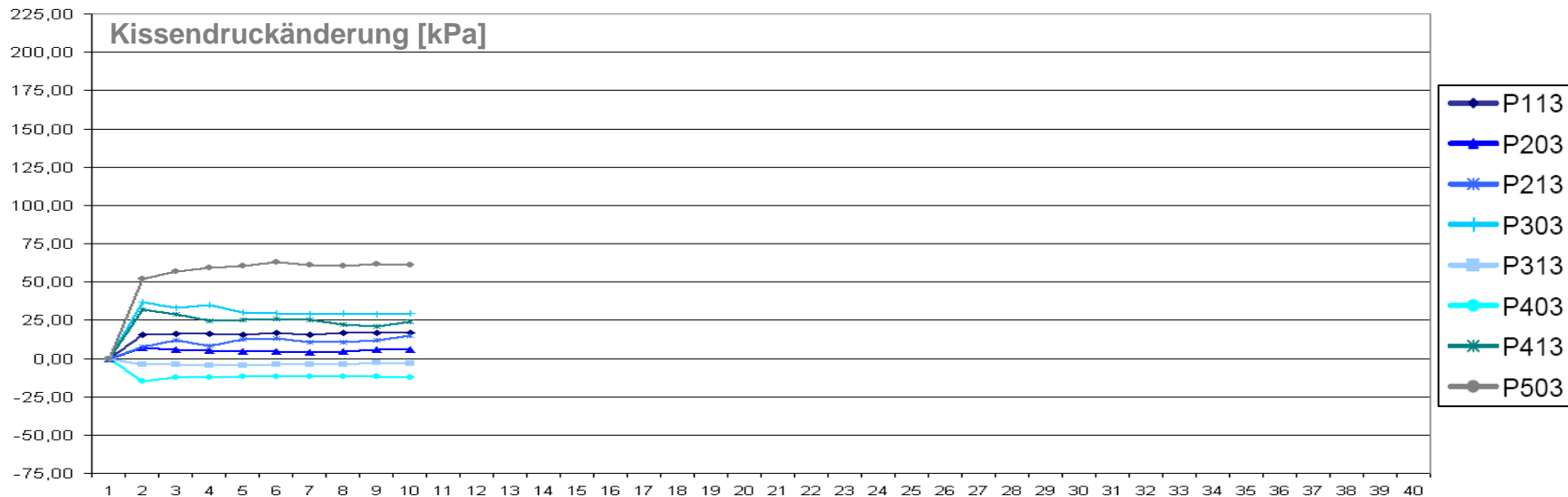
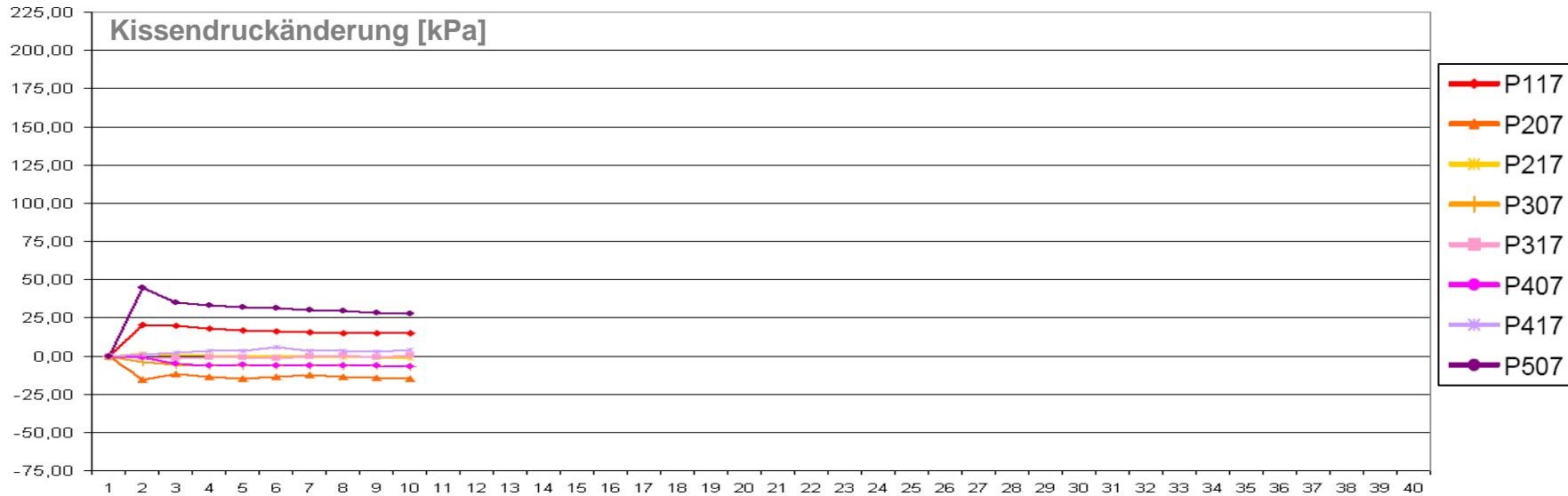

# Kissendruckänderung im Rohrkämpfer

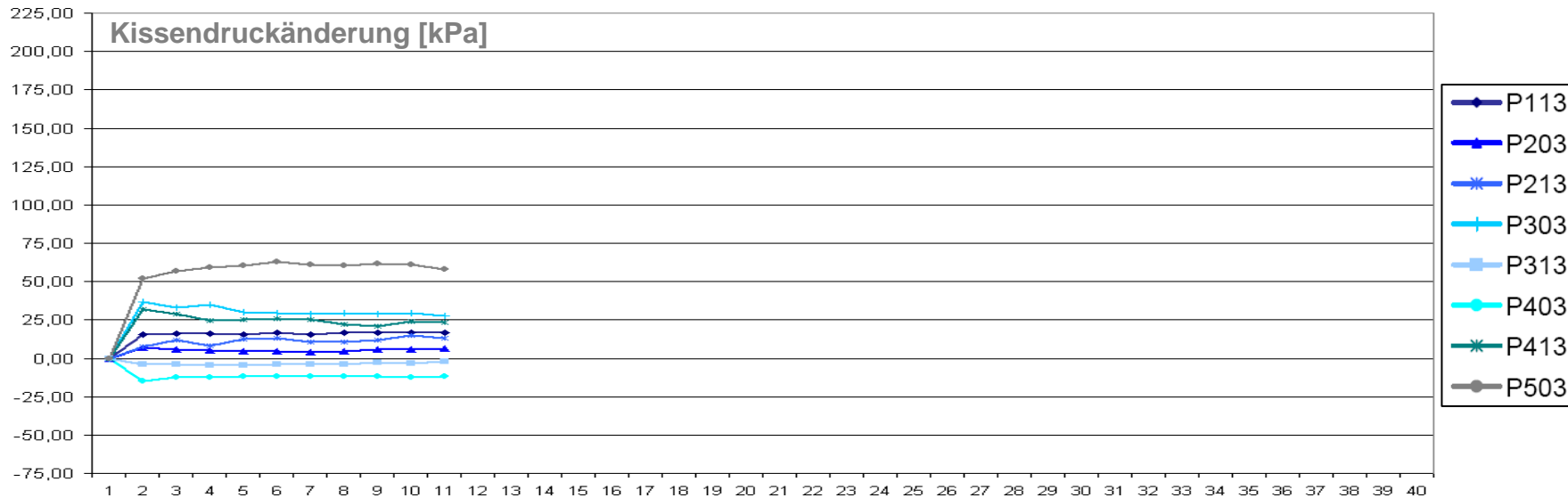
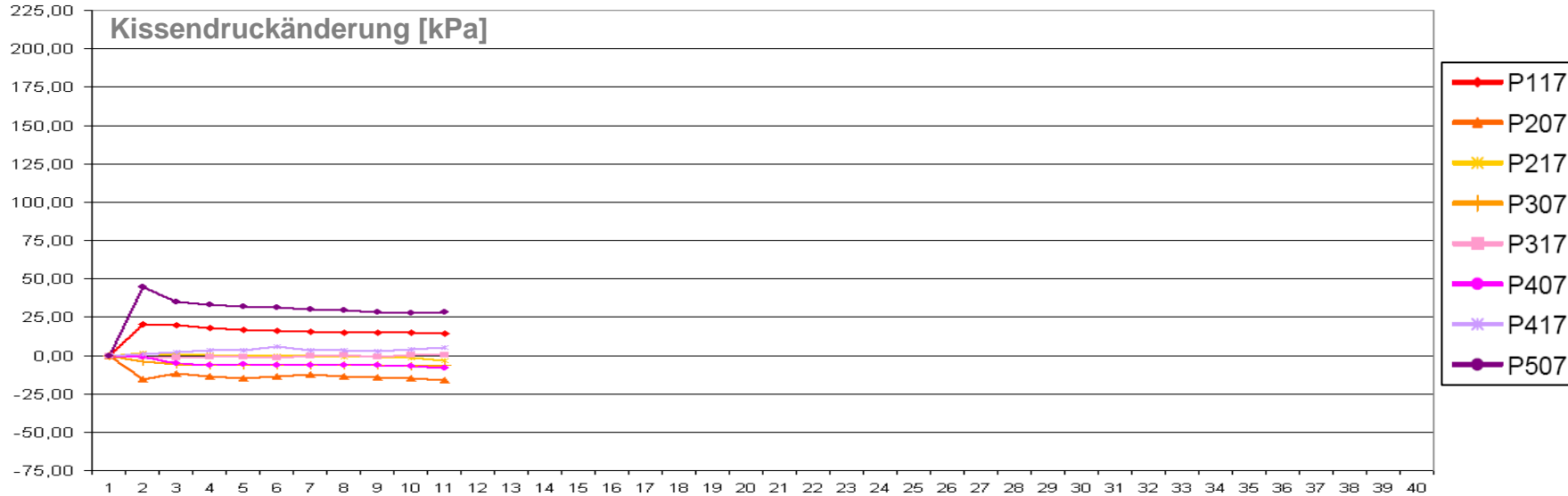



# Kissendruckänderung im Rohrkämpfer

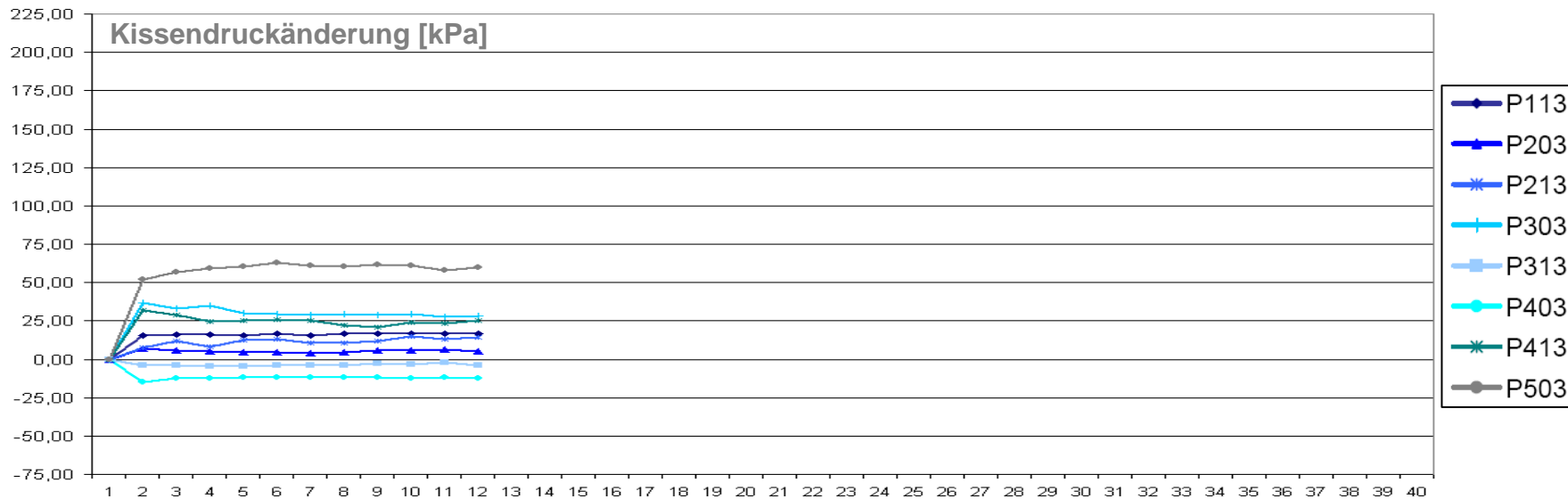
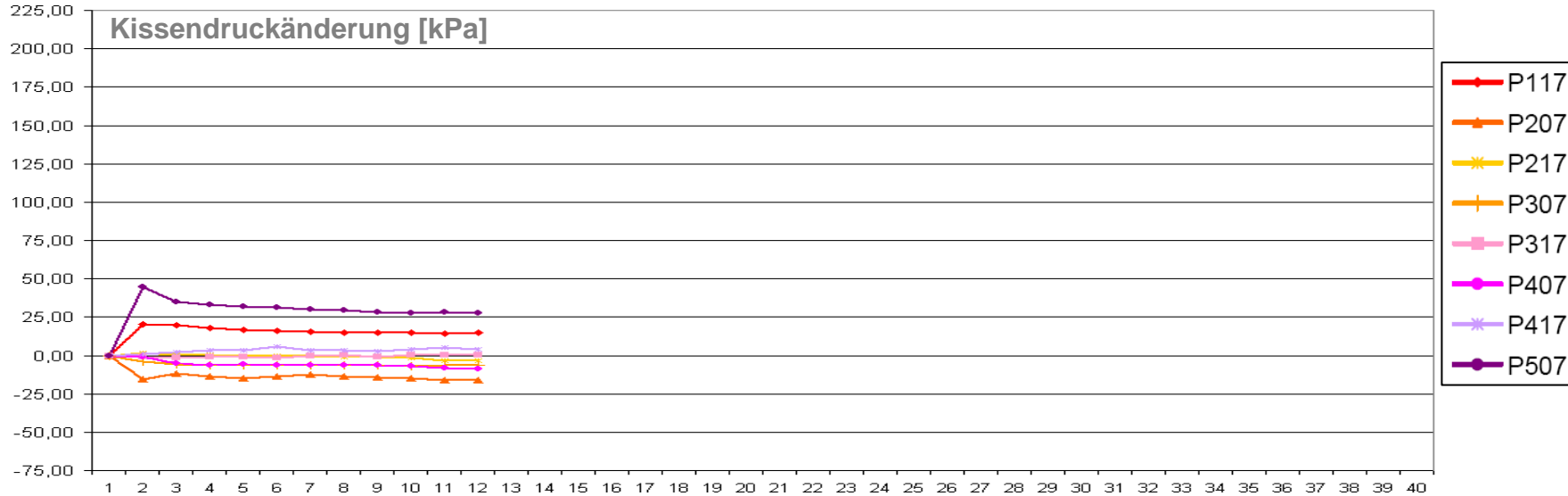

# Kissendruckänderung im Rohrkämpfer

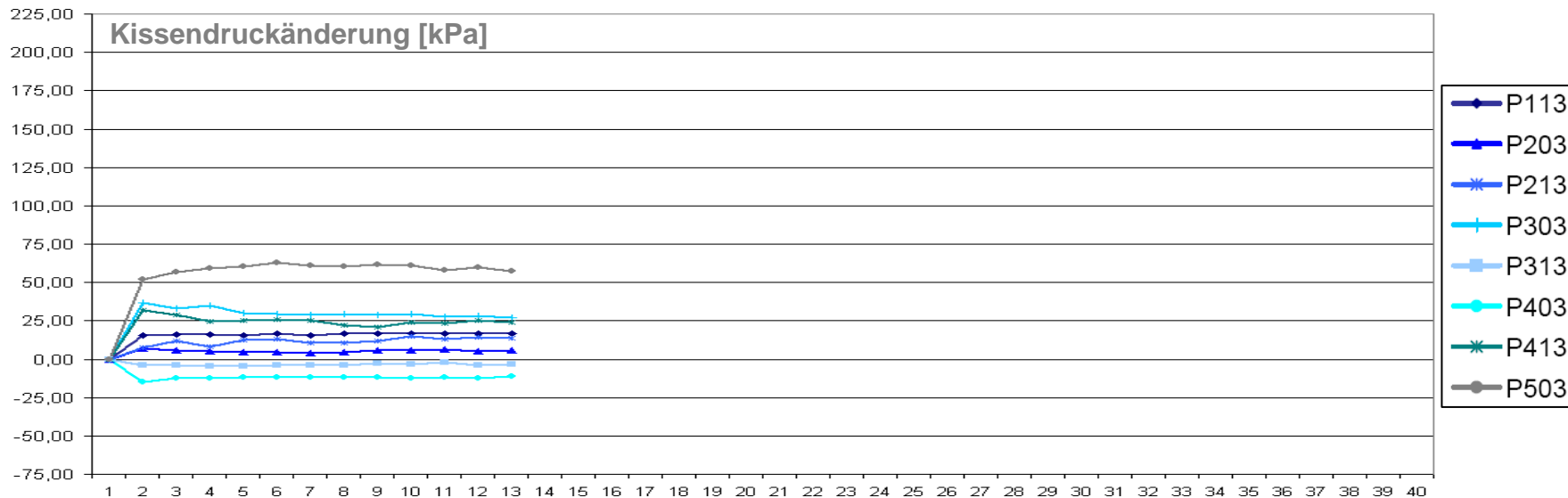
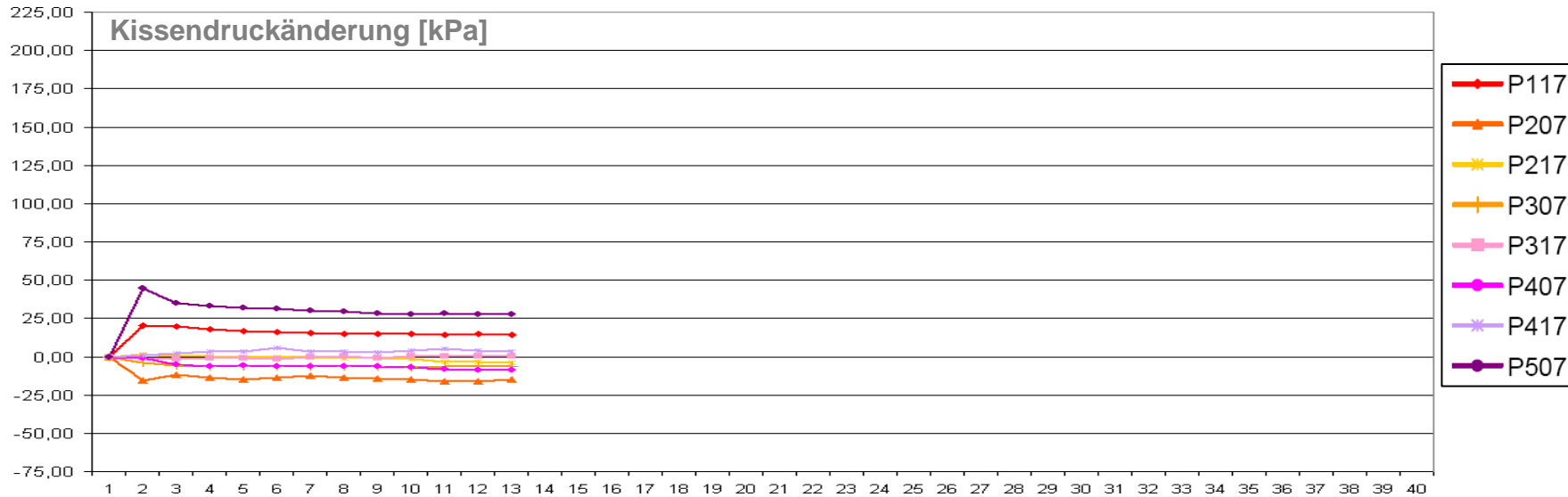

# Kissendruckänderung im Rohrkämpfer

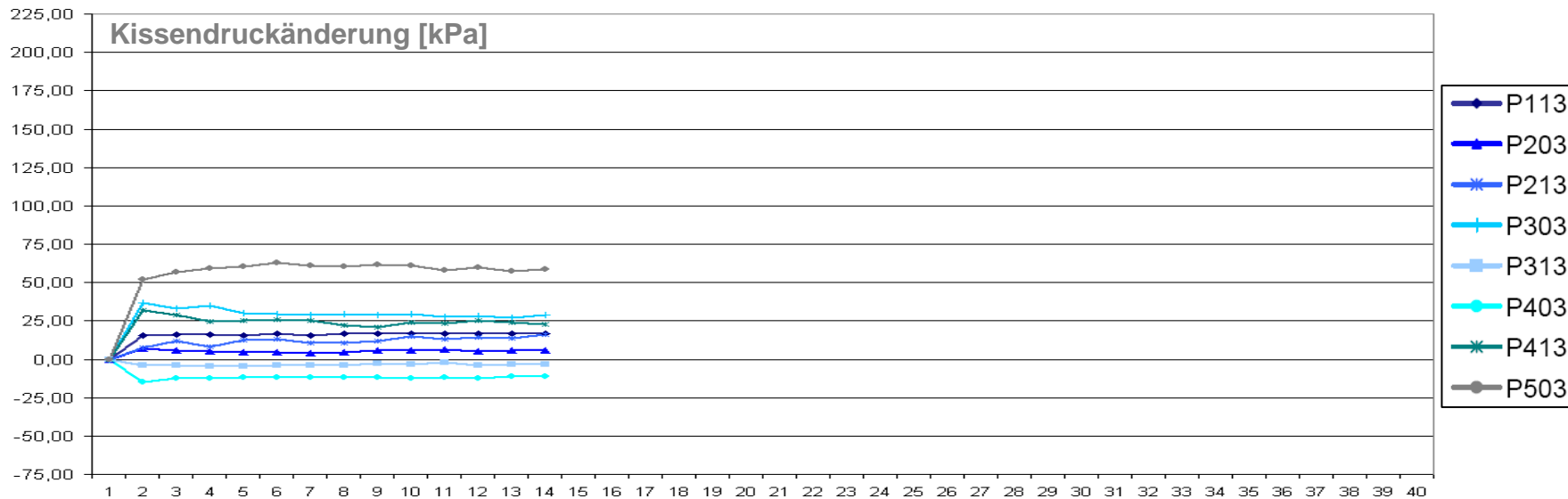
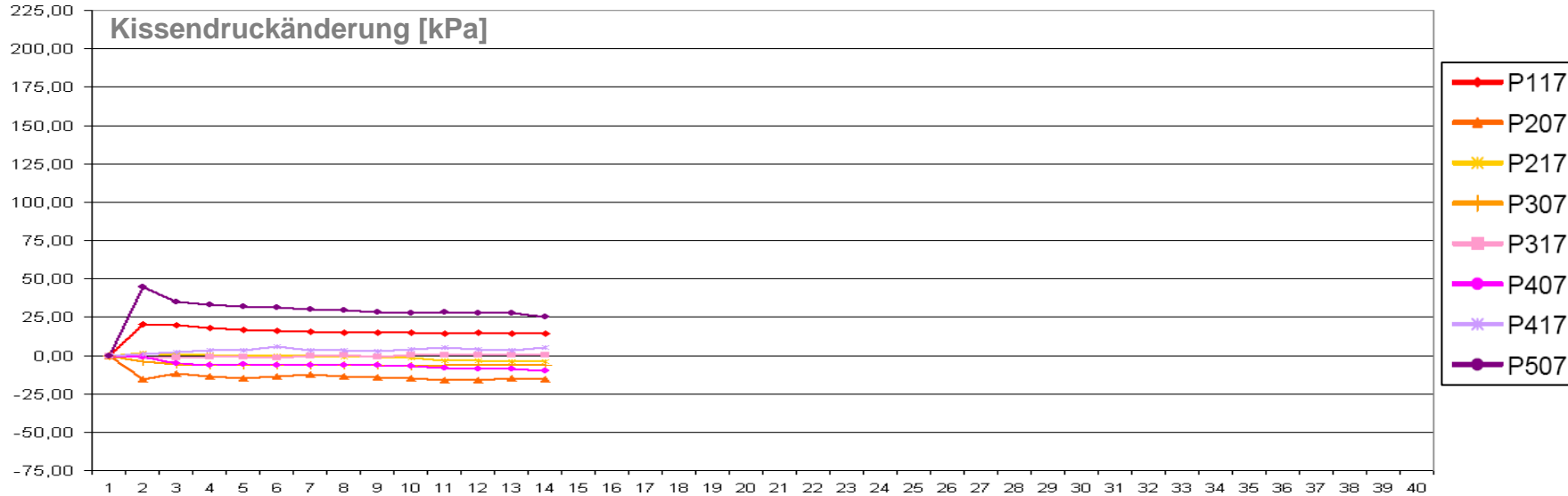

# Kissendruckänderung im Rohrkämpfer

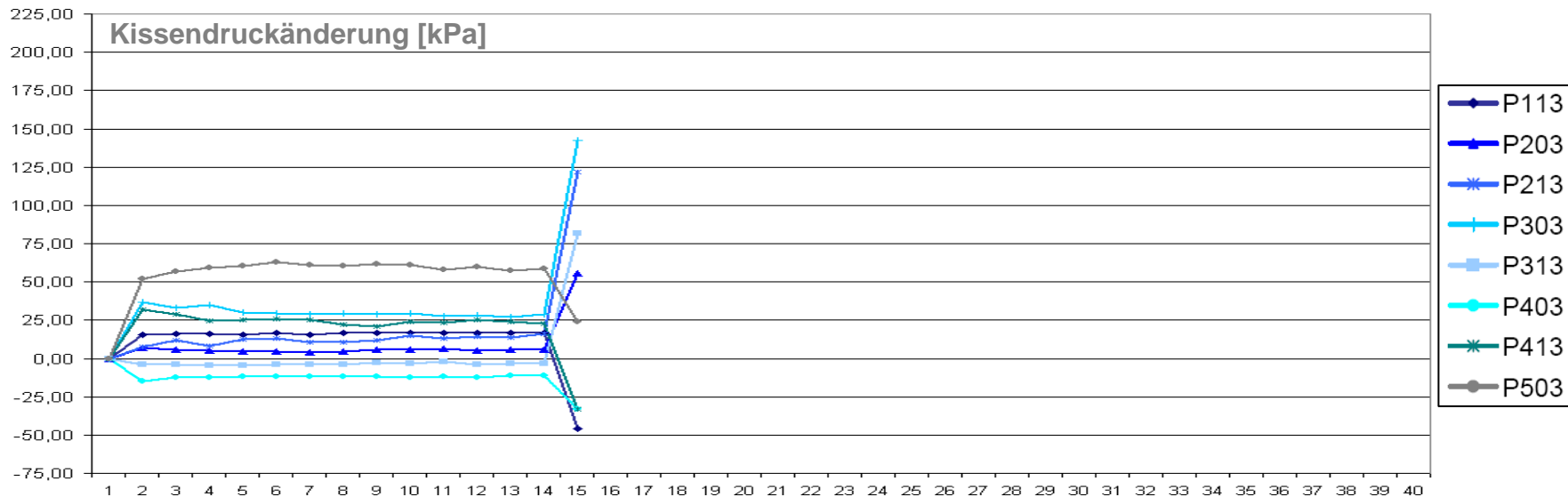
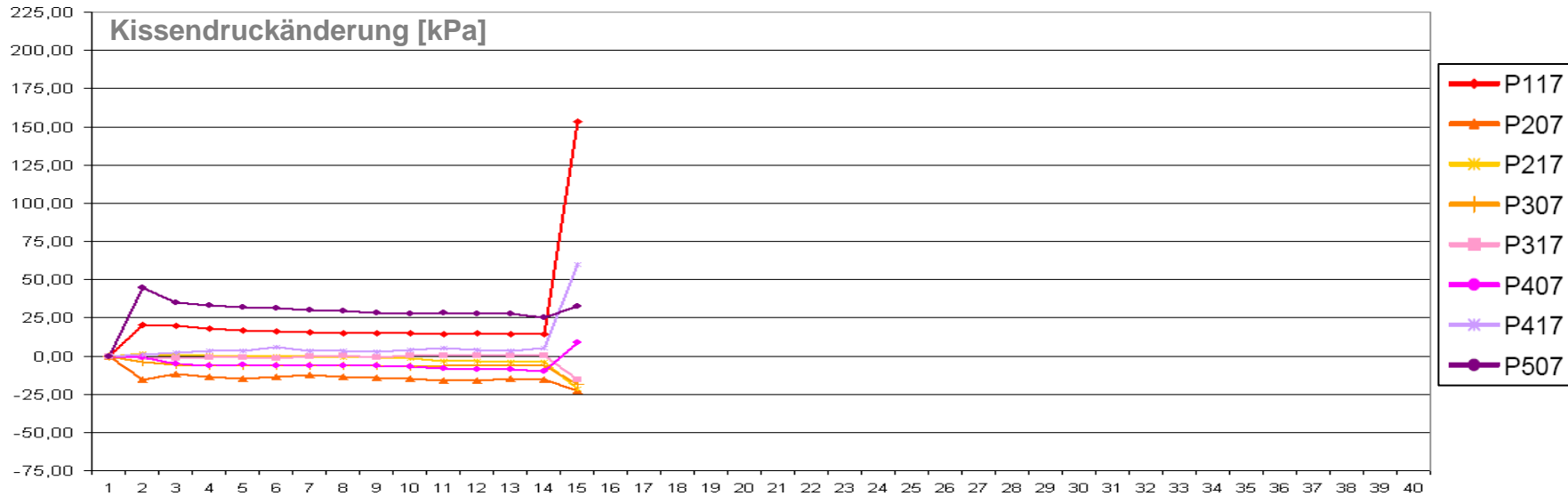

# Kissendruckänderung im Rohrkämpfer

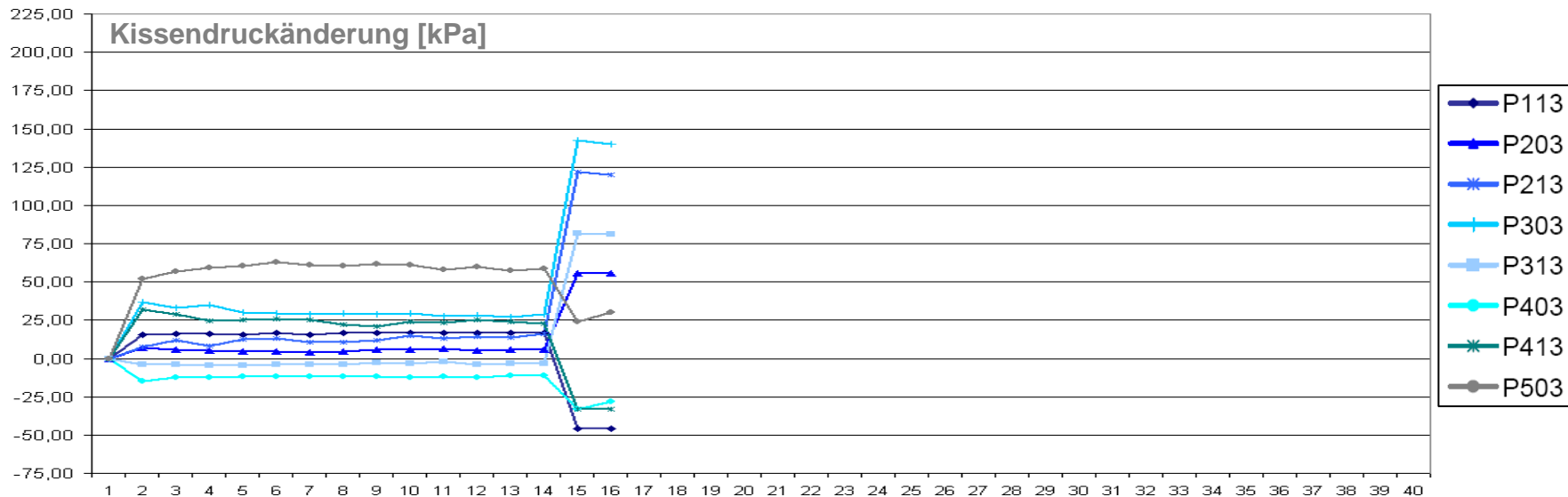
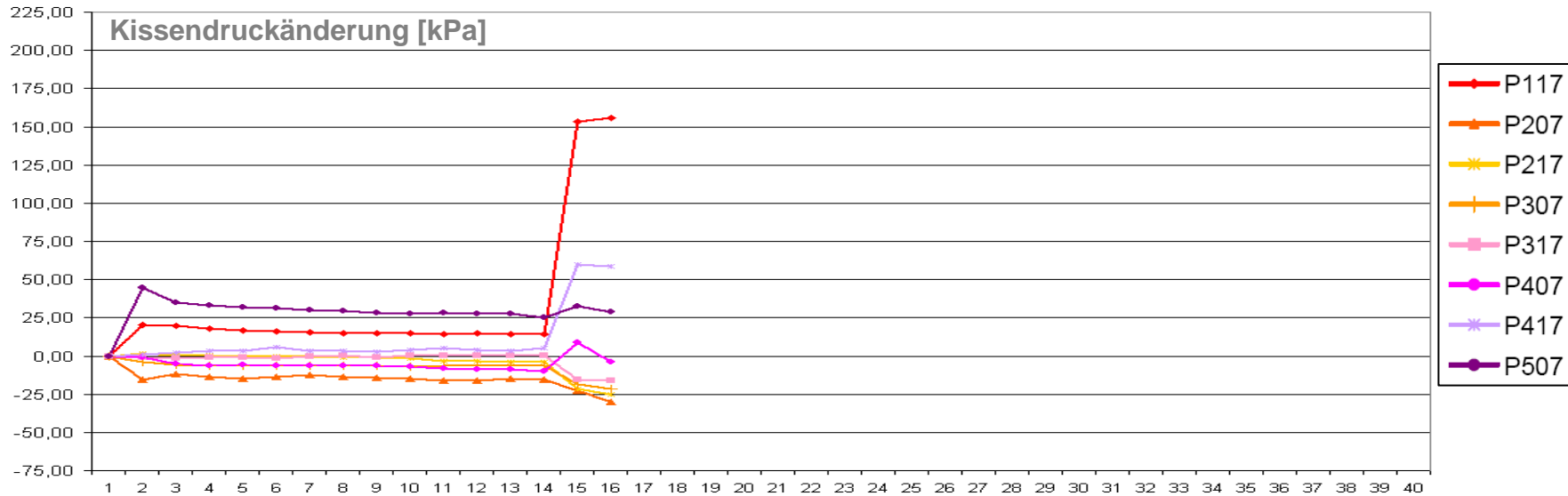

# Kissendruckänderung im Rohrkämpfer

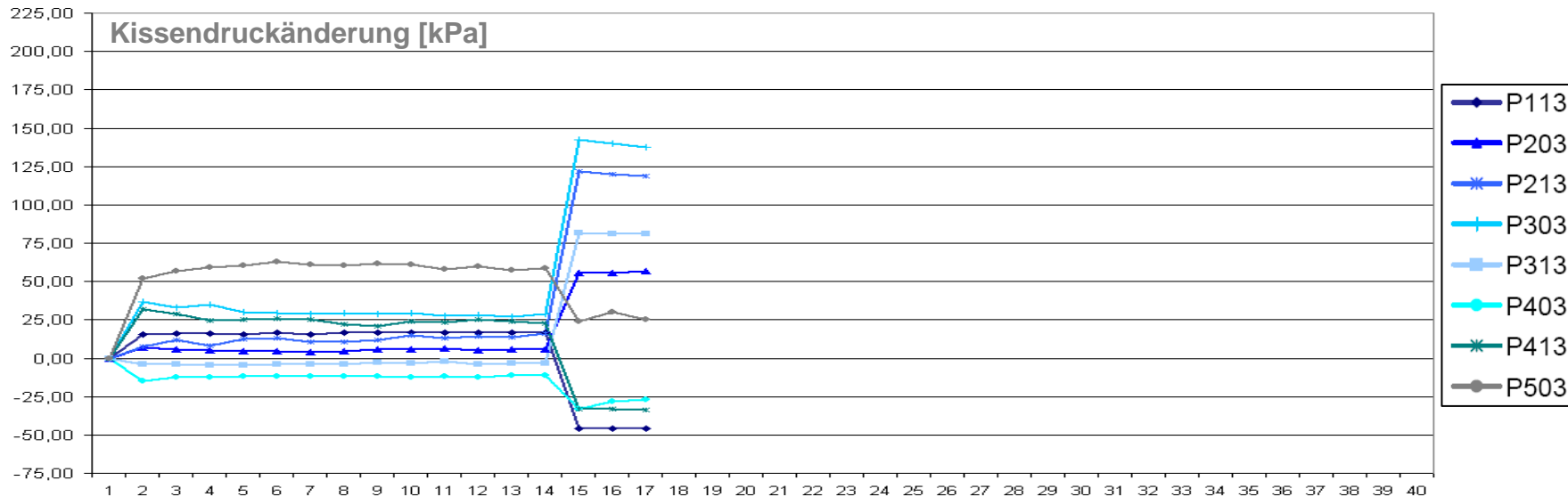
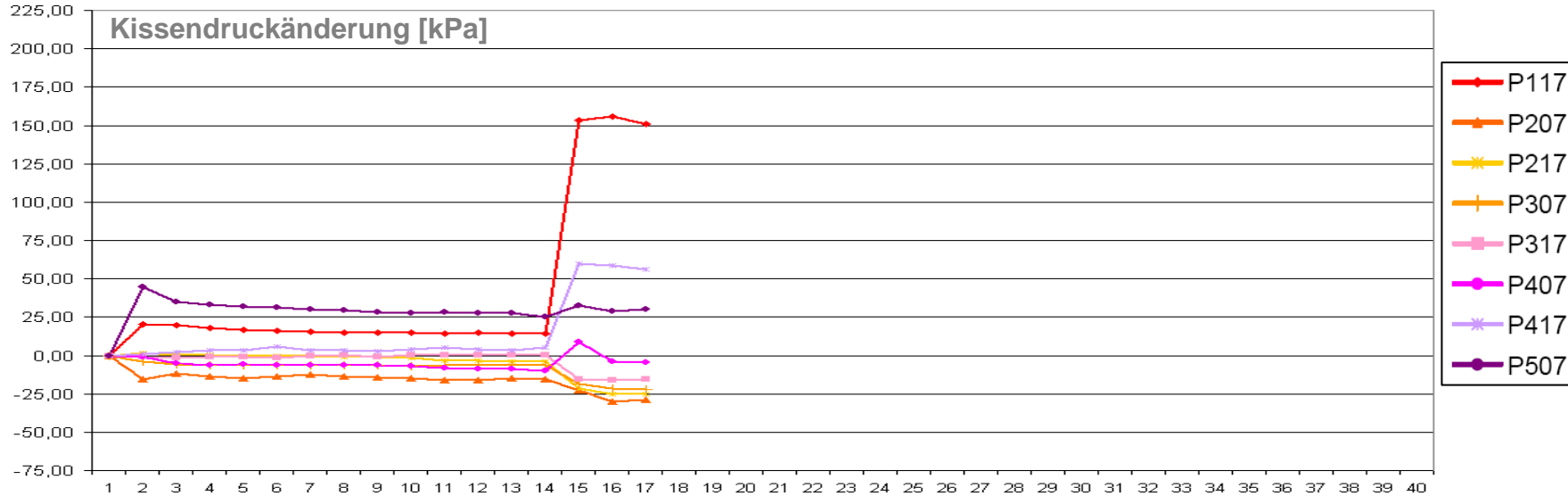

# Kissendruckänderung im Rohrkämpfer

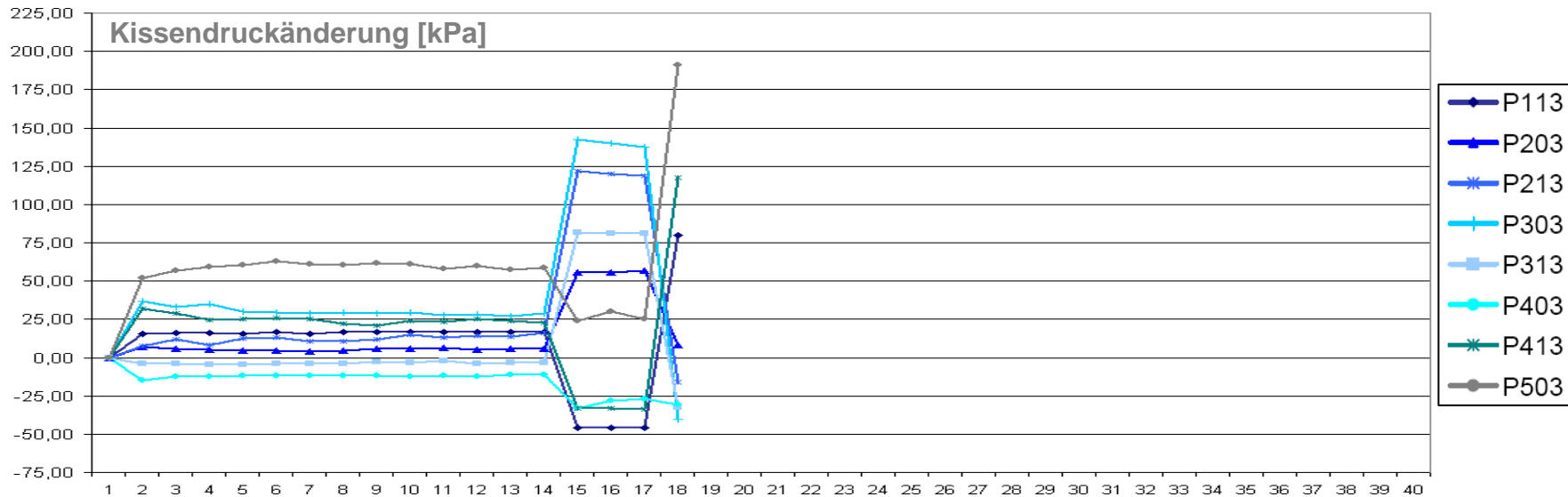
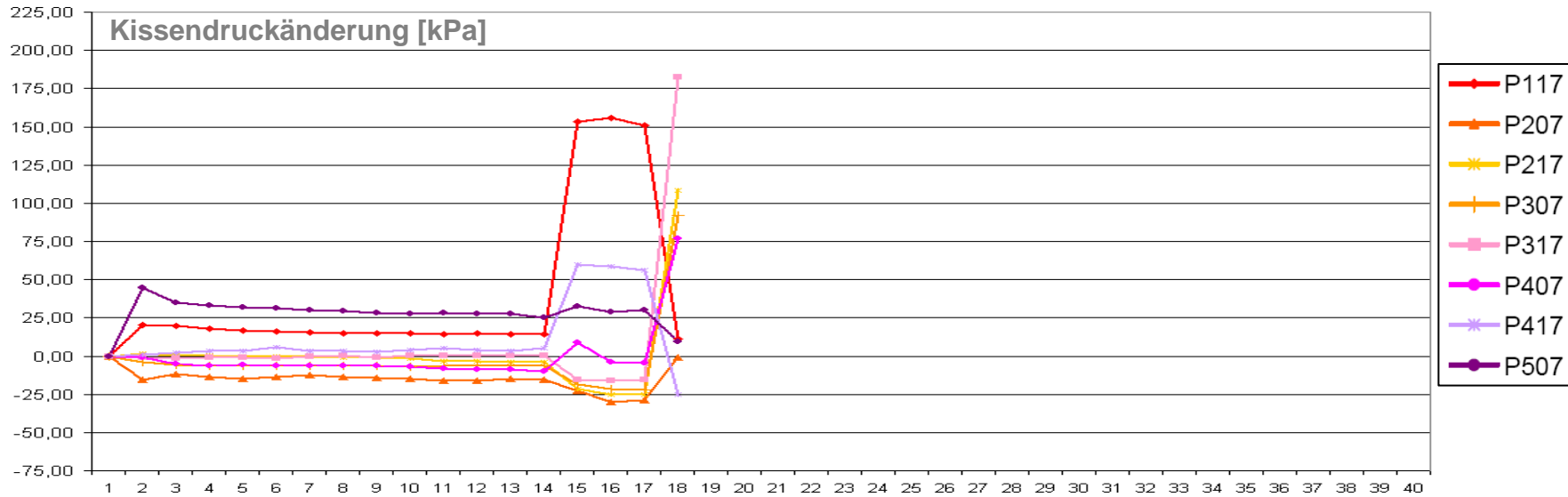





# Kissendruckänderung im Rohrkämpfer

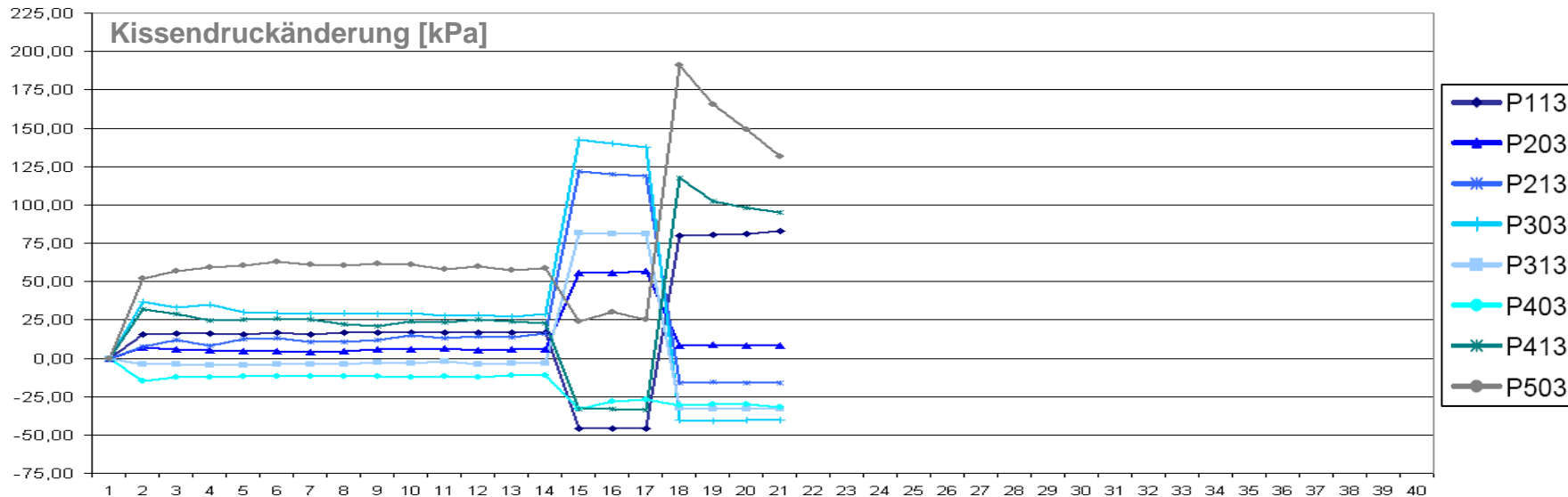
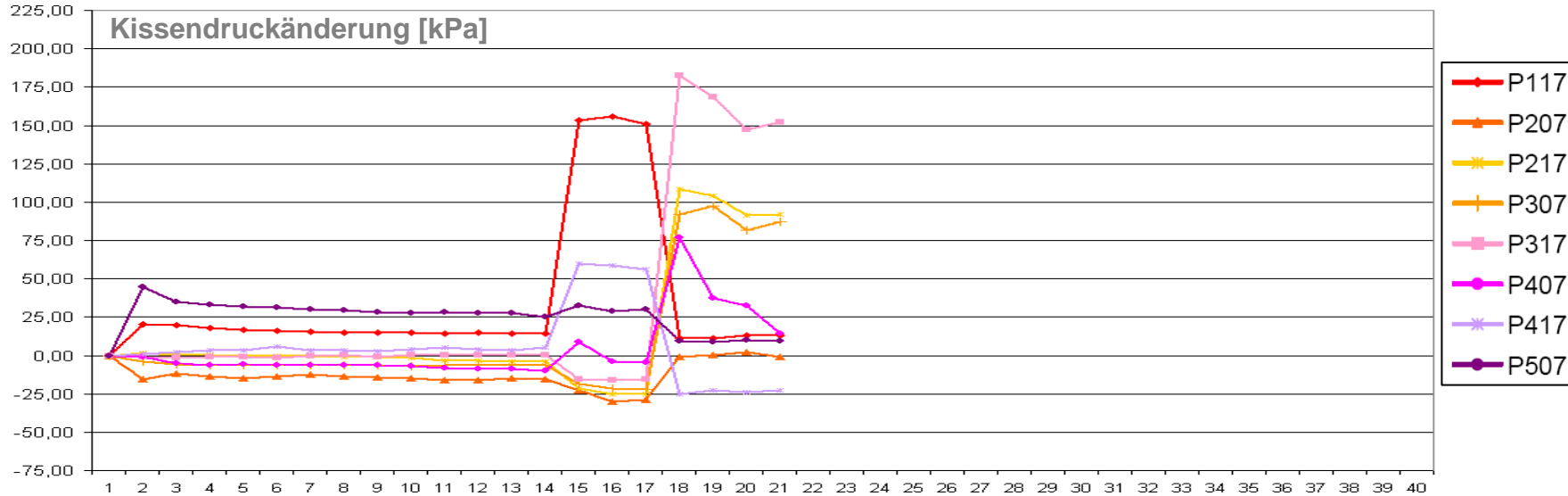

# Kissendruckänderung im Rohrkämpfer

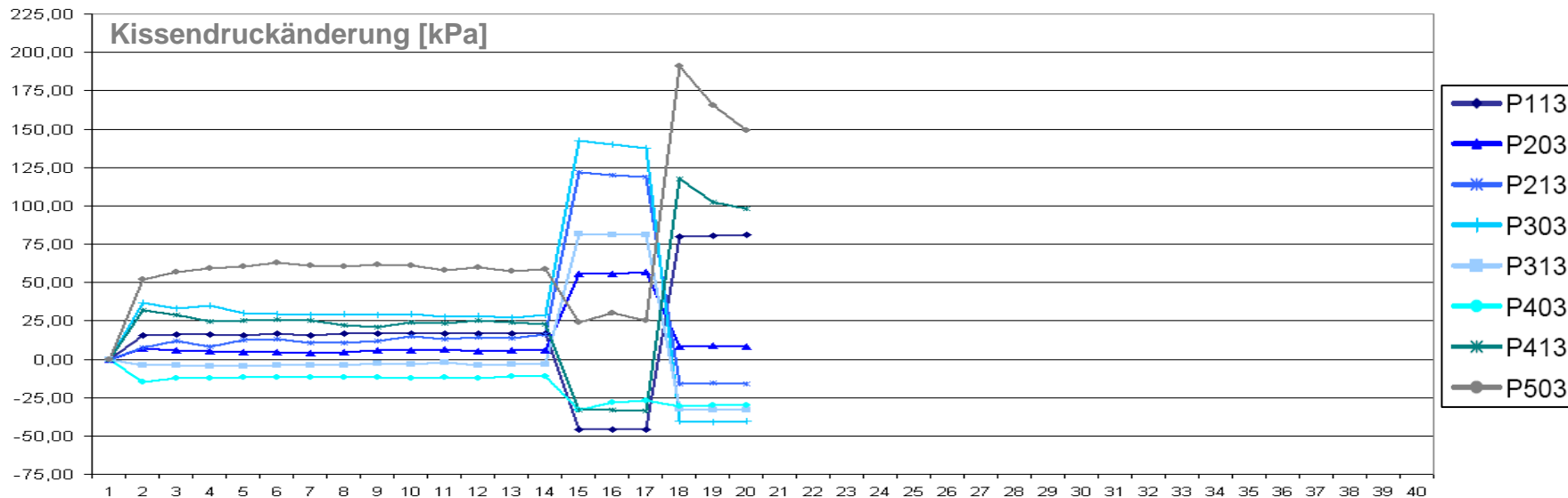
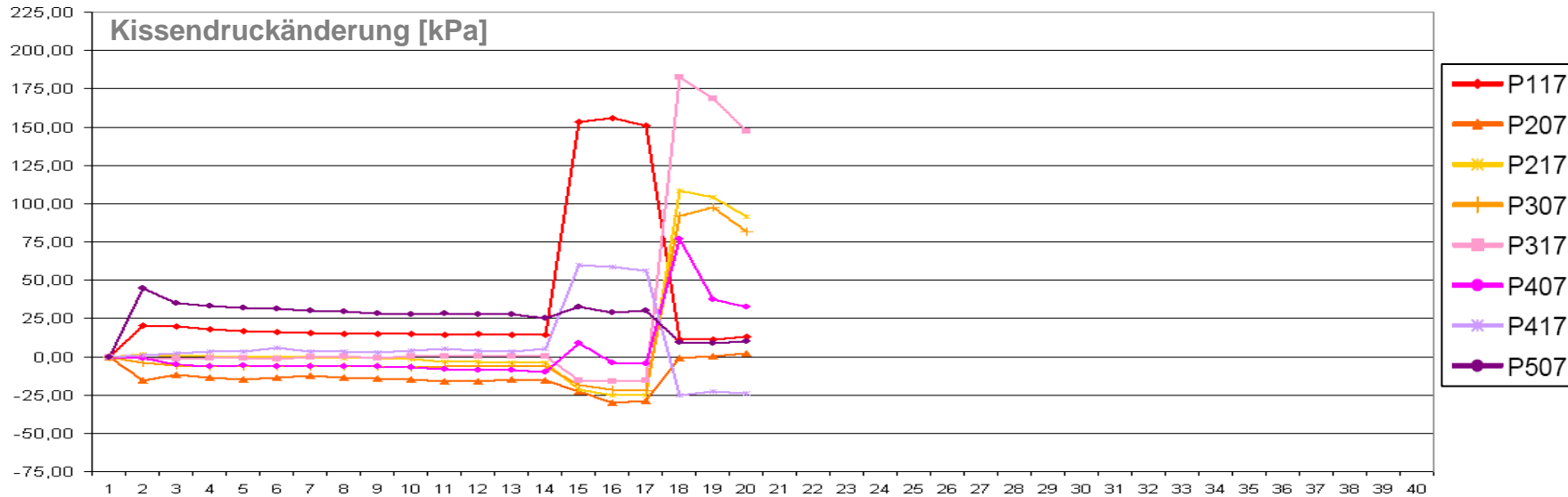

# Kissendruckänderung im Rohrkämpfer

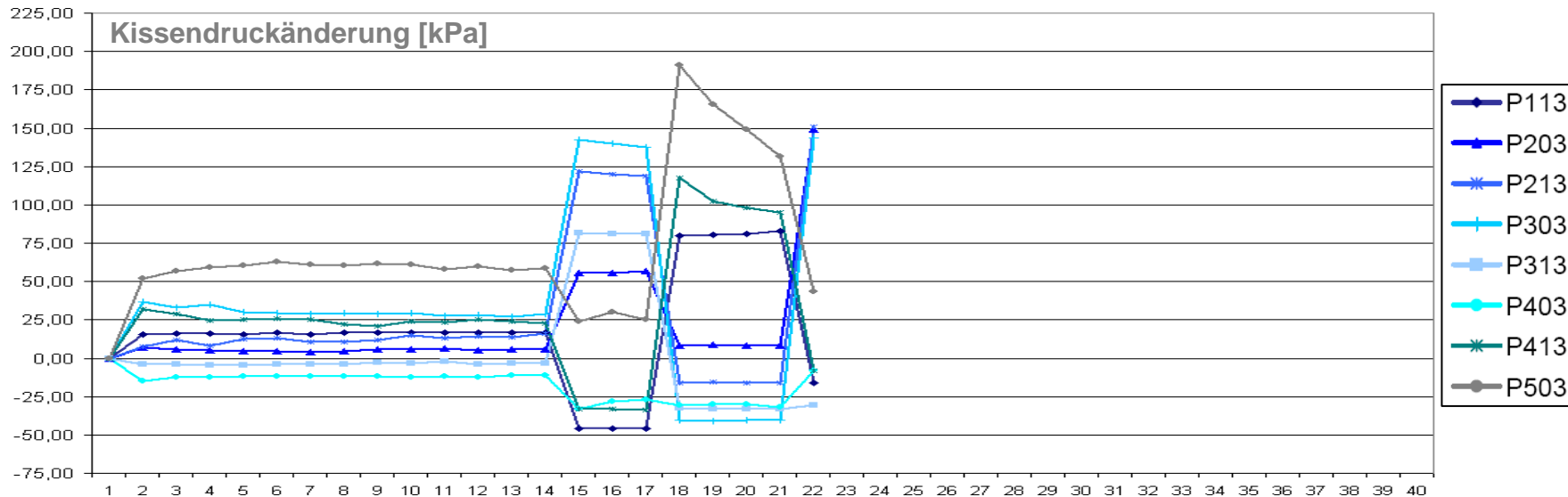
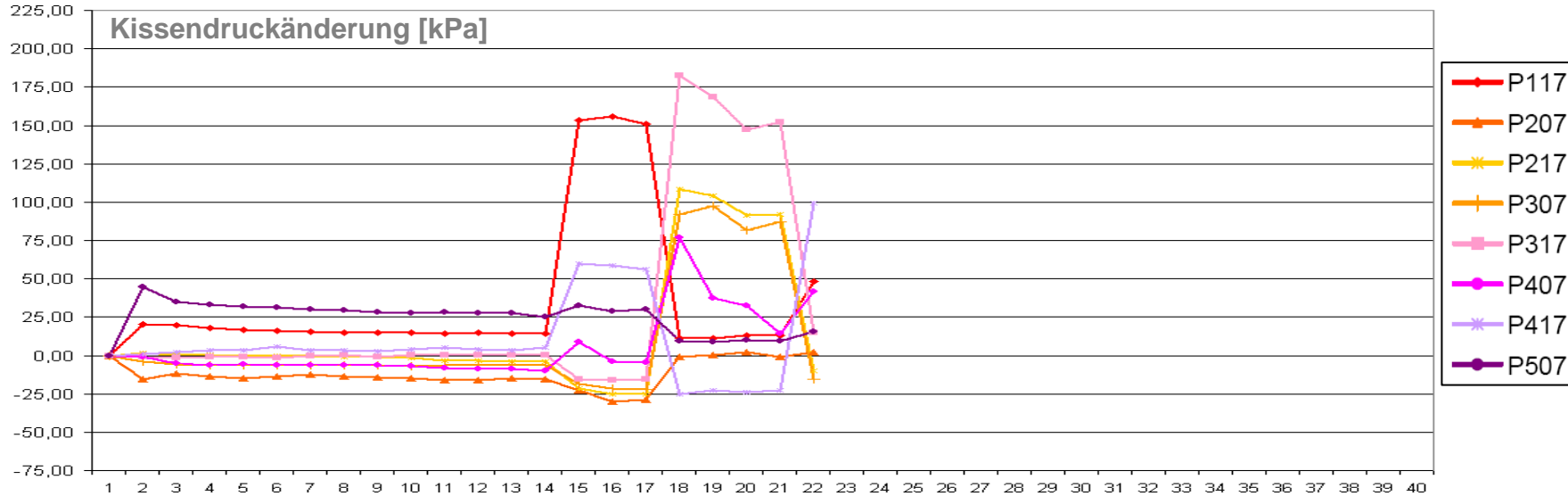

# Kissendruckänderung im Rohrkämpfer

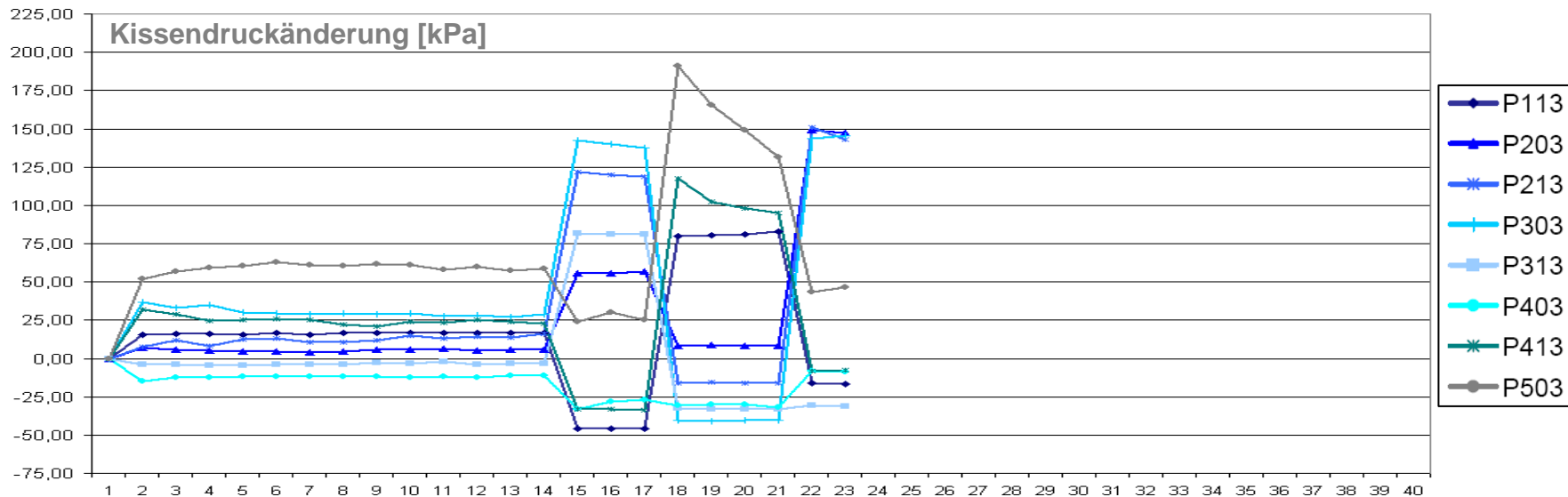
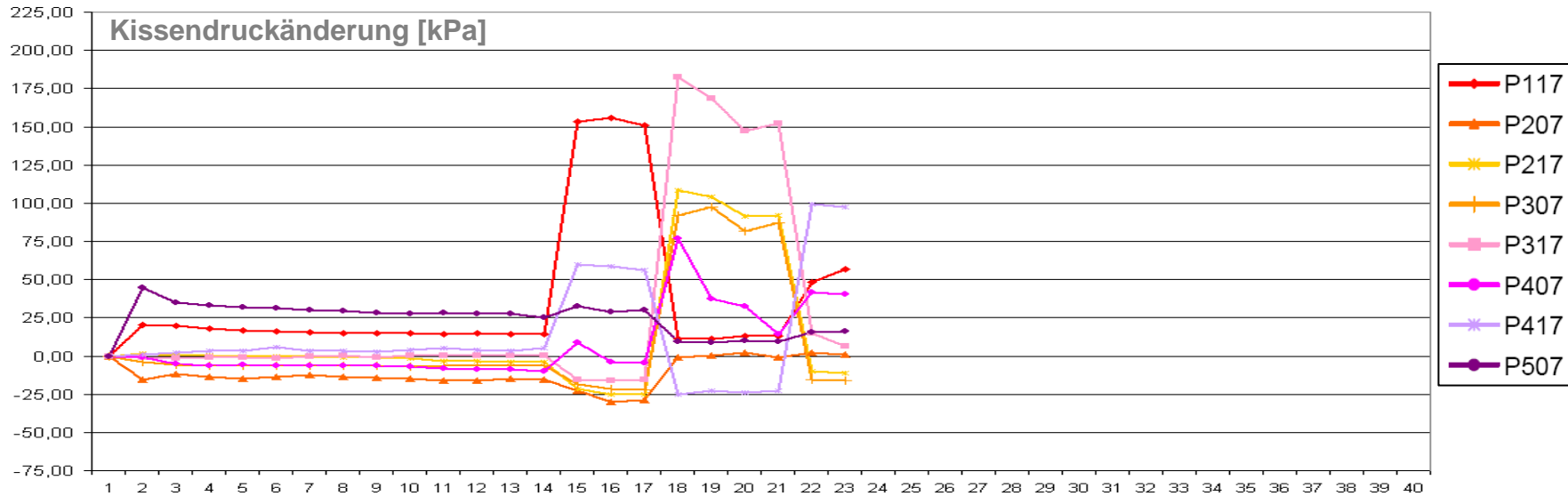

# Kissendruckänderung im Rohrkämpfer

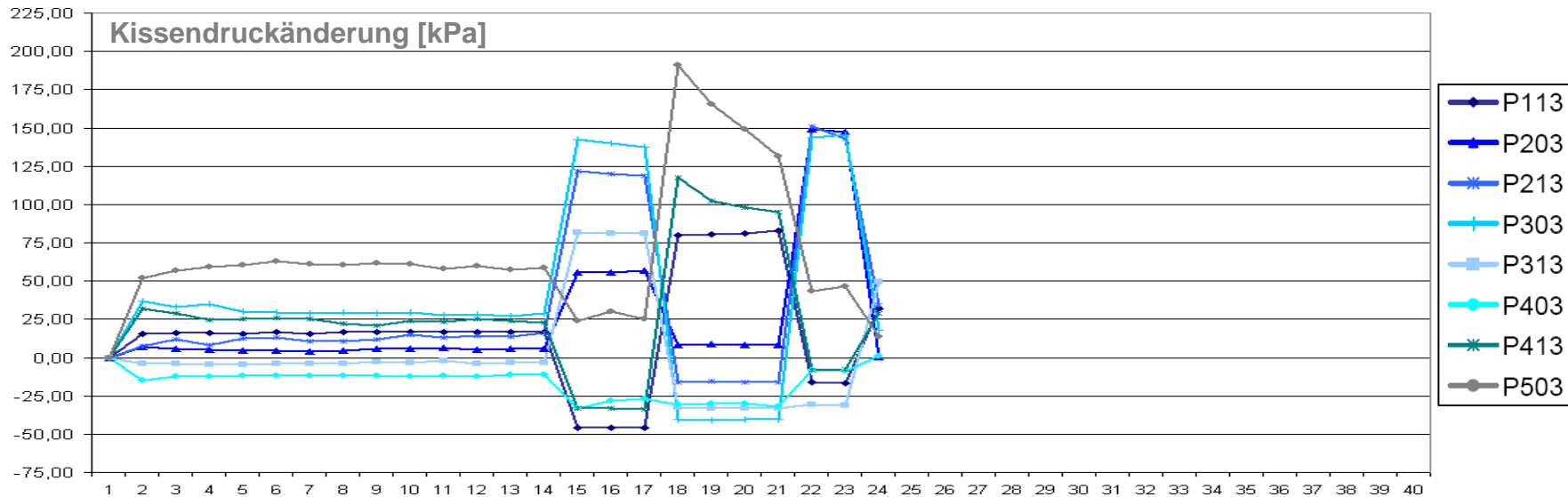
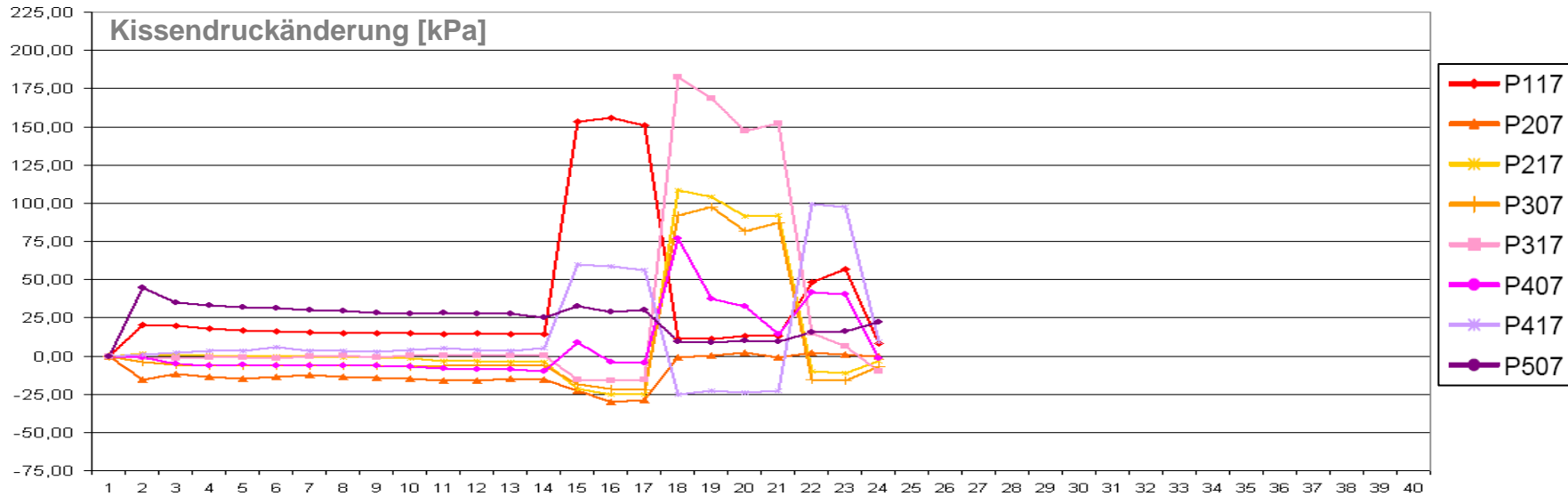

# Kissendruckänderung im Rohrkämpfer

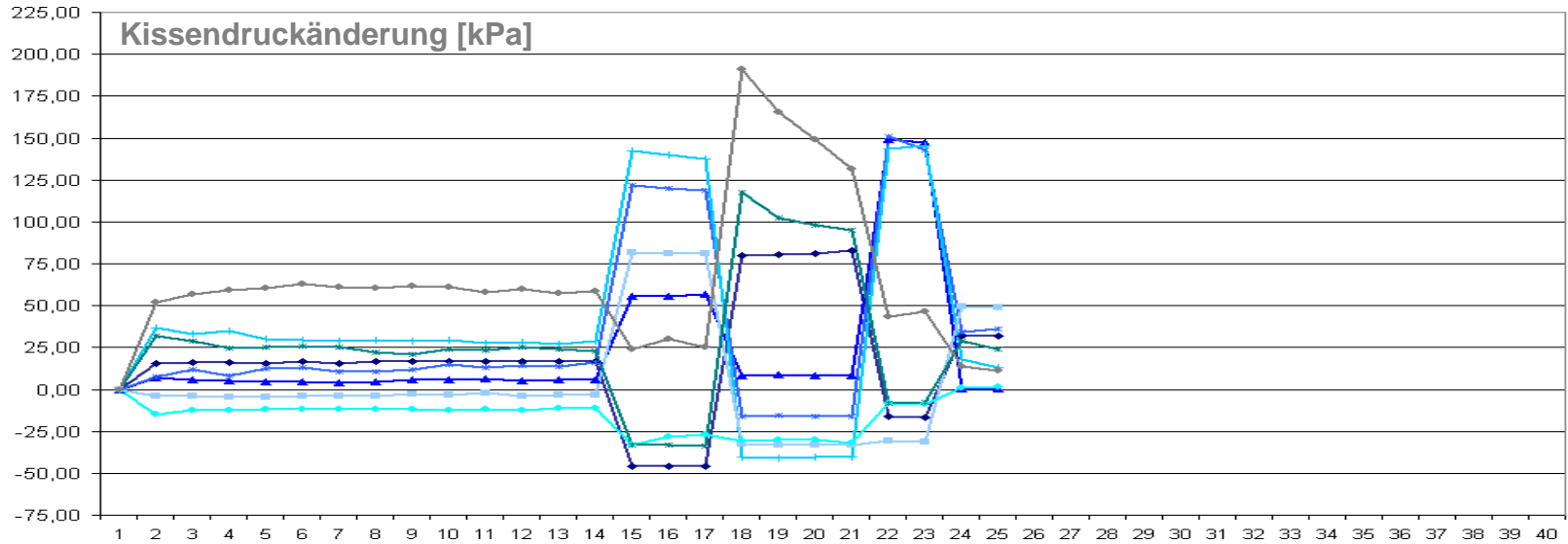
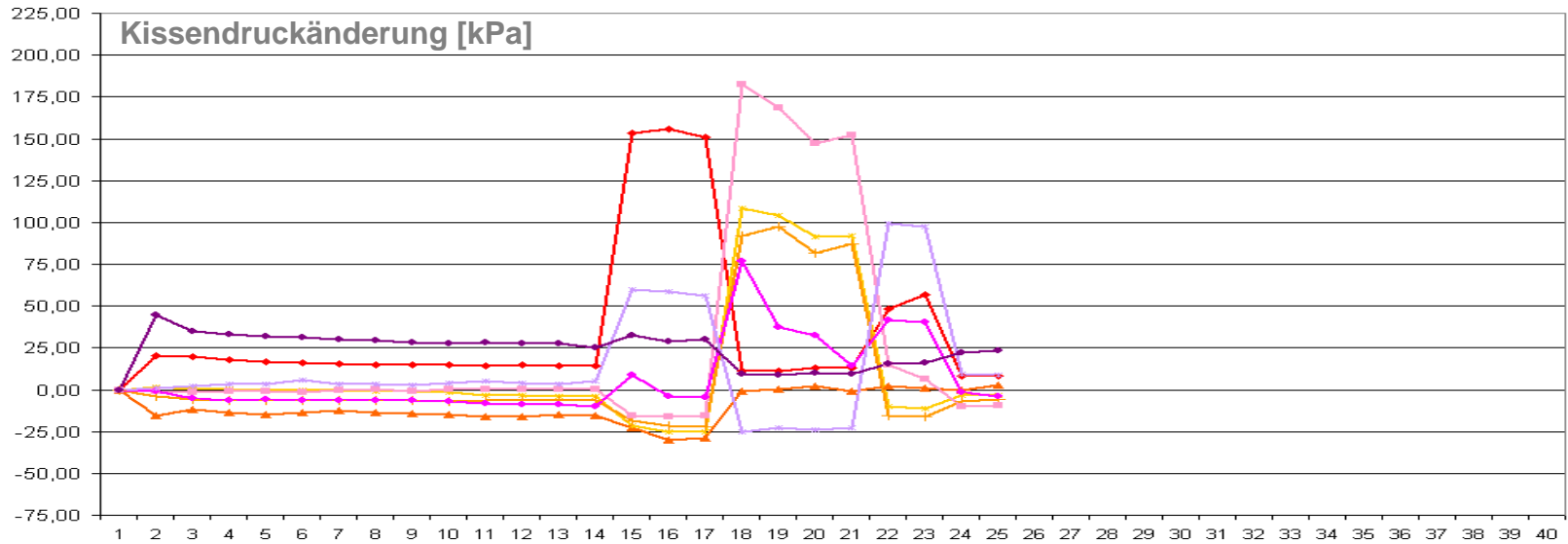

# Kissendruckänderung im Rohrkämpfer

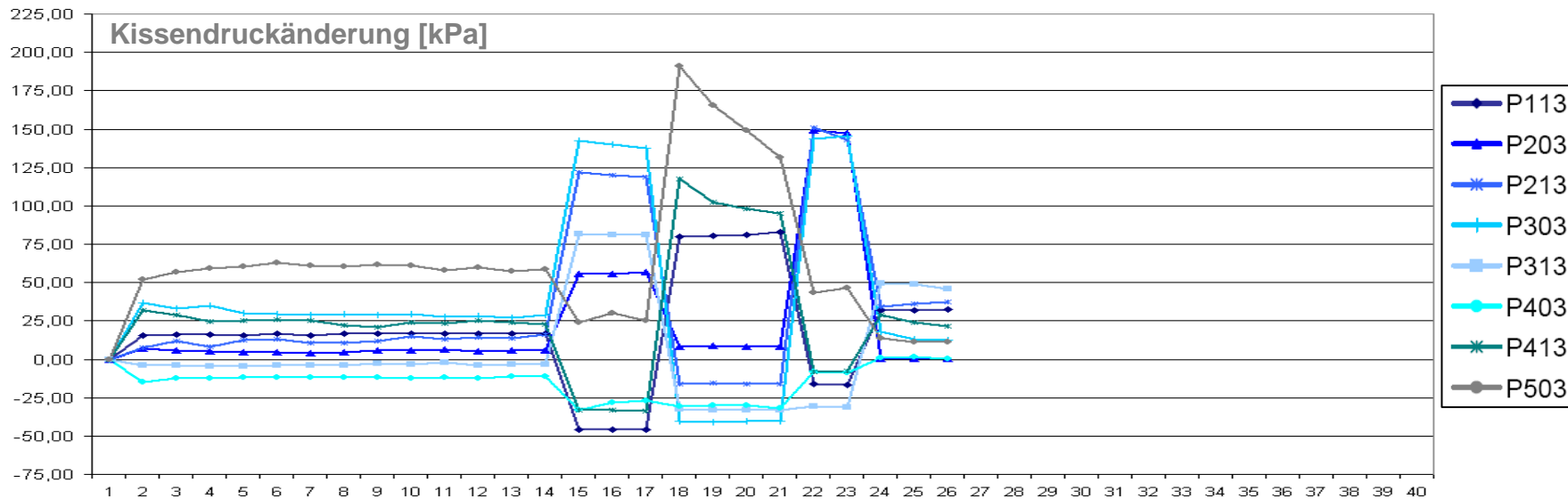
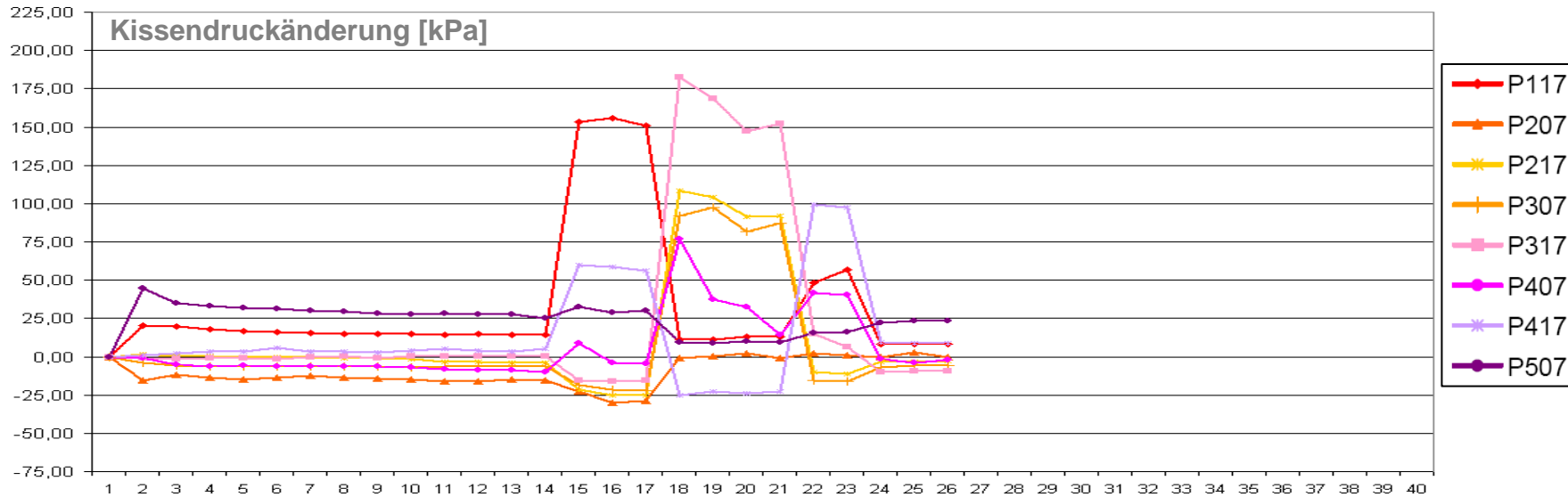





# Kissendruckänderung im Rohrkämpfer

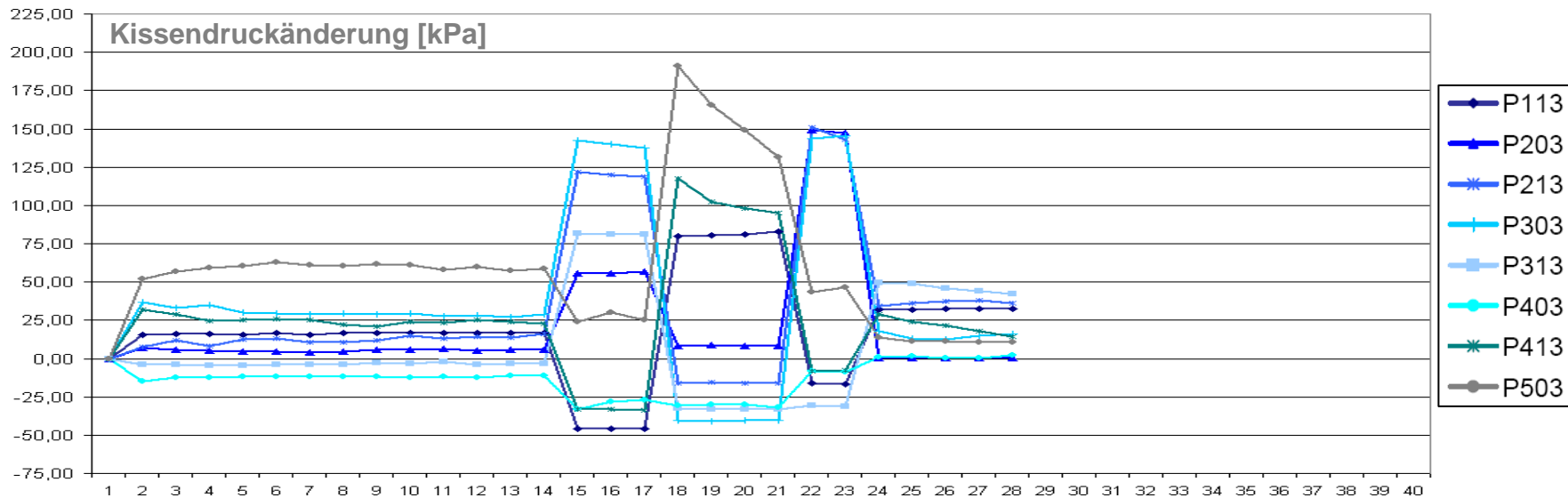
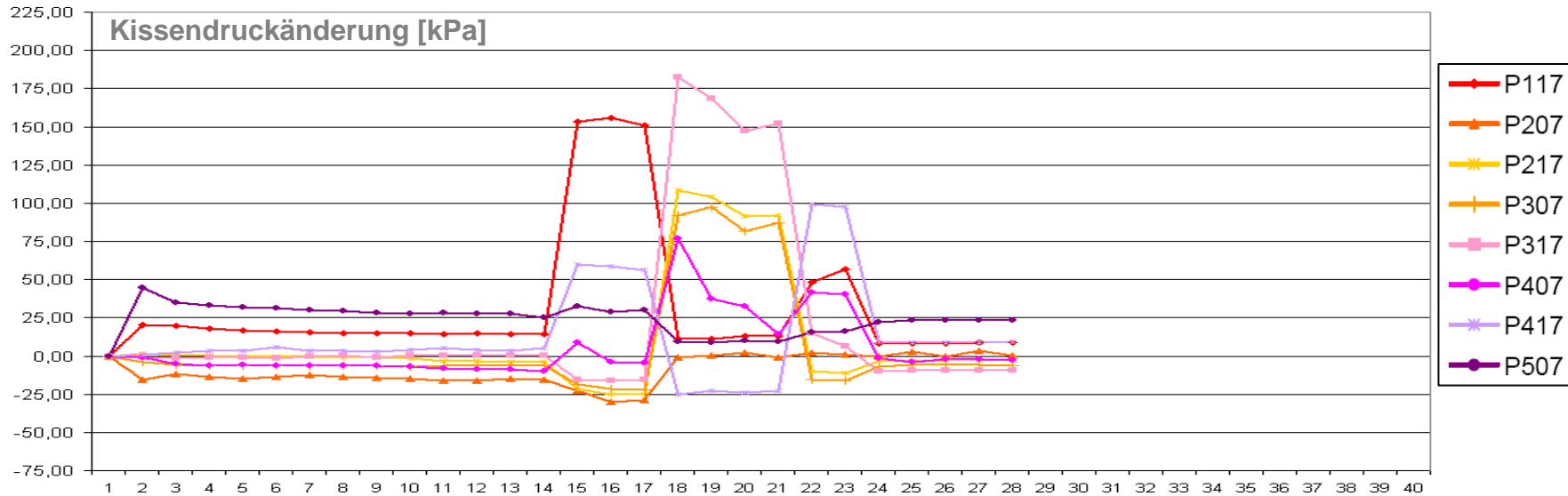

# Kissendruckänderung im Rohrkämpfer

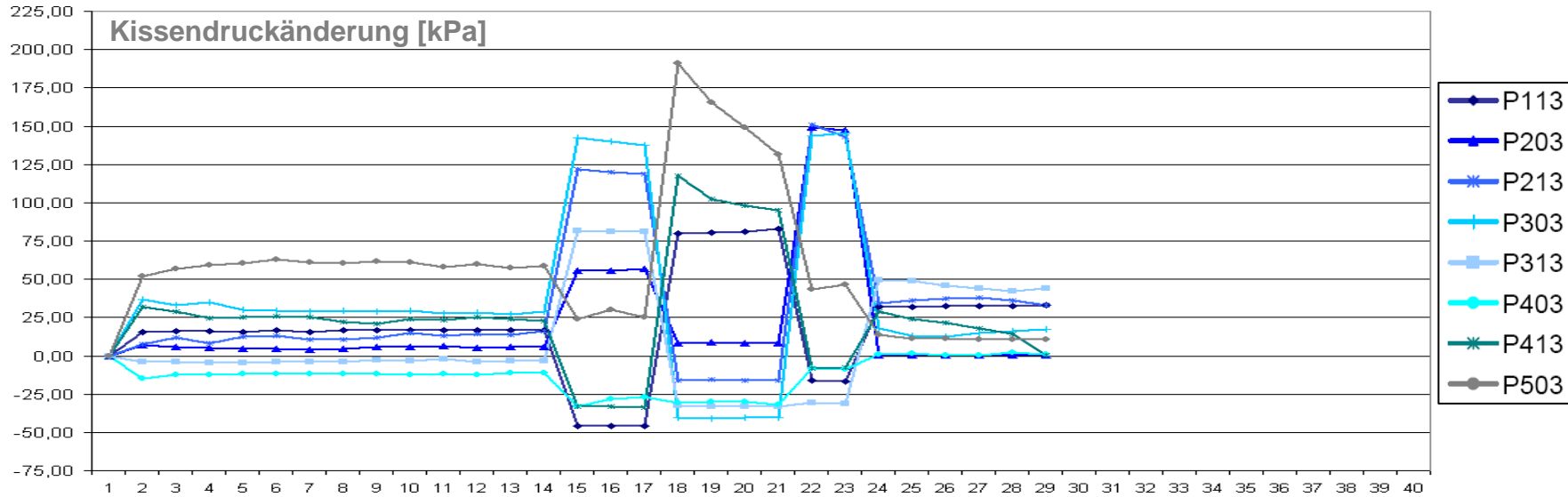
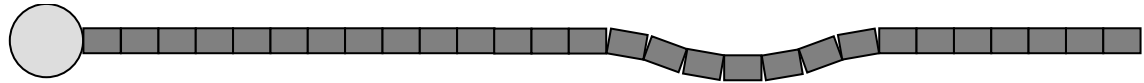
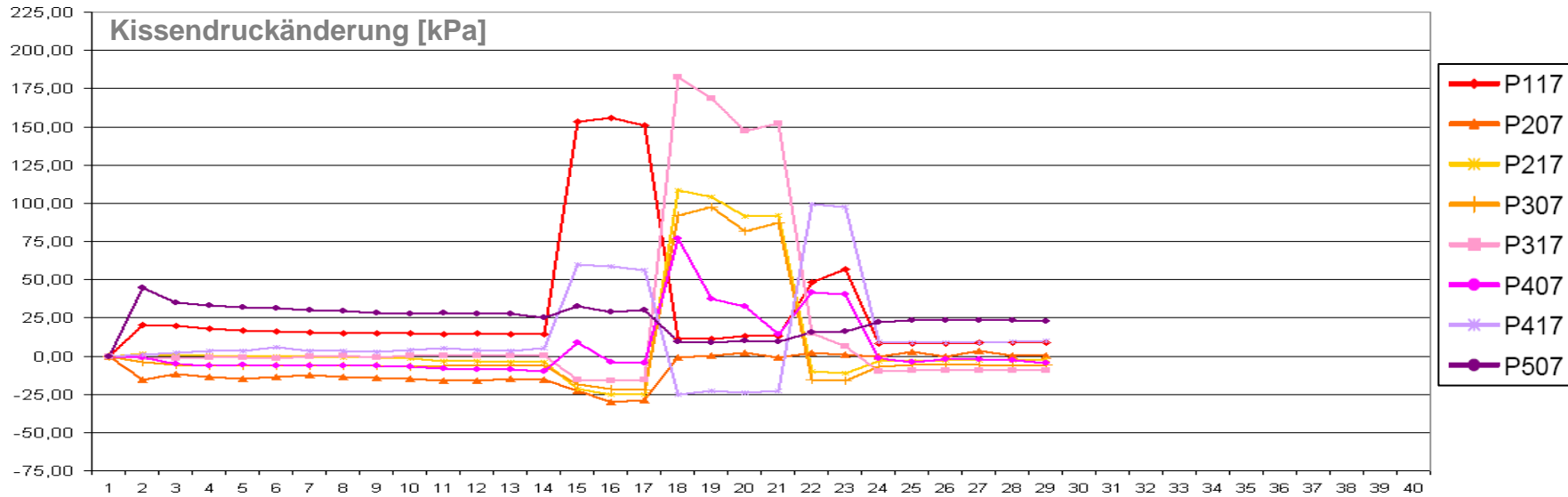



# Kissendruckänderung im Rohrkämpfer

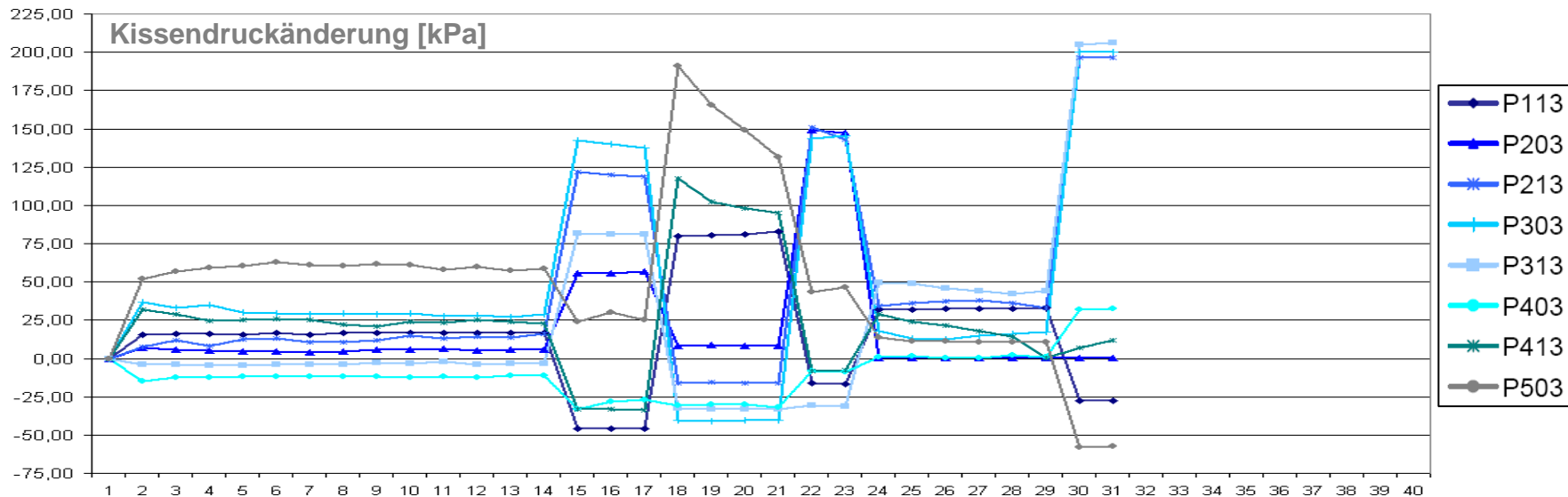
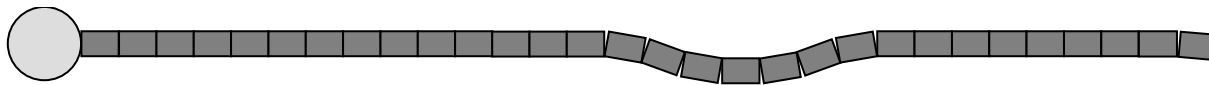
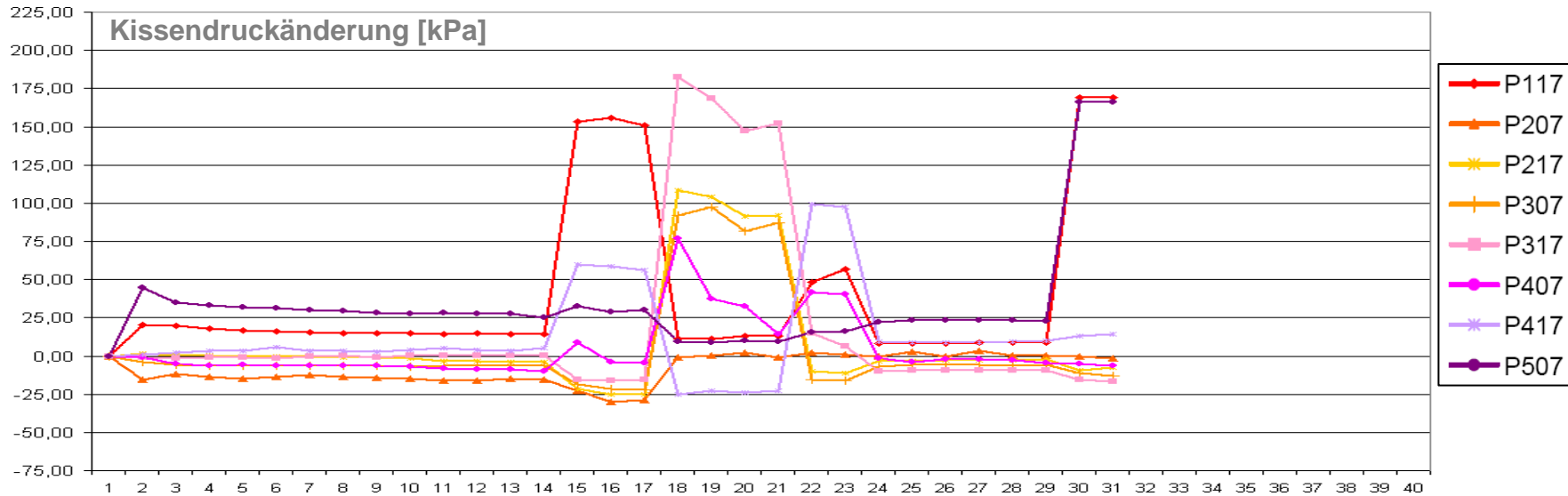

# Kissendruckänderung im Rohrkämpfer

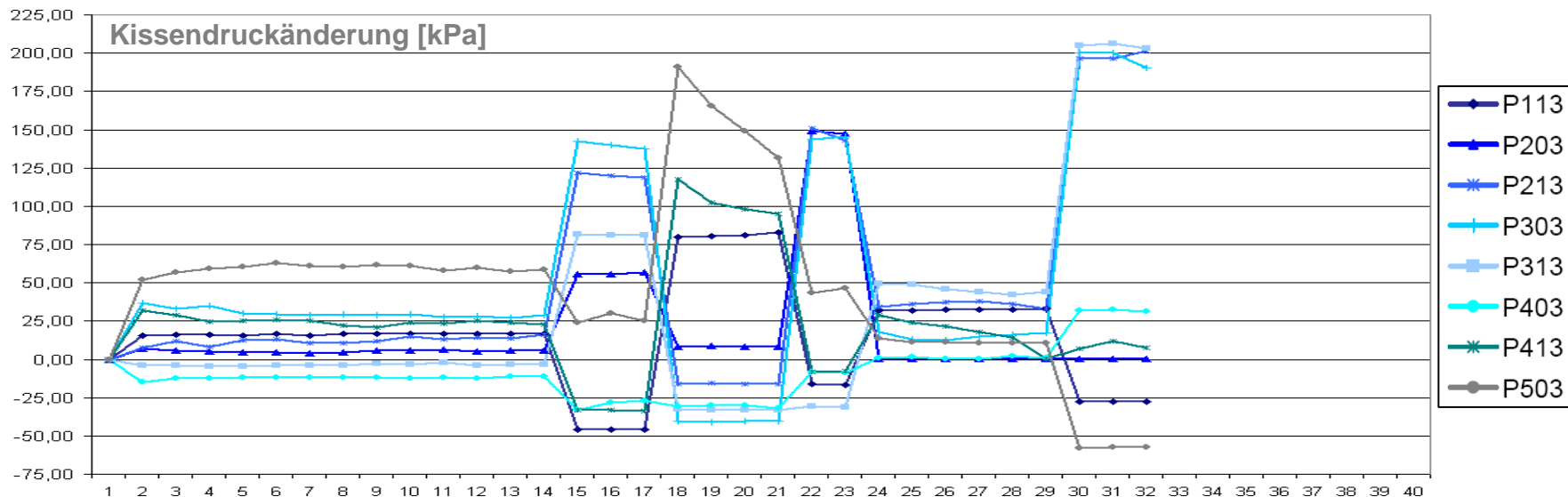
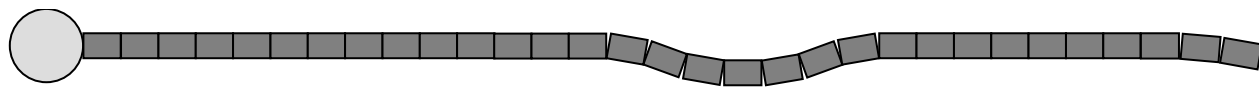
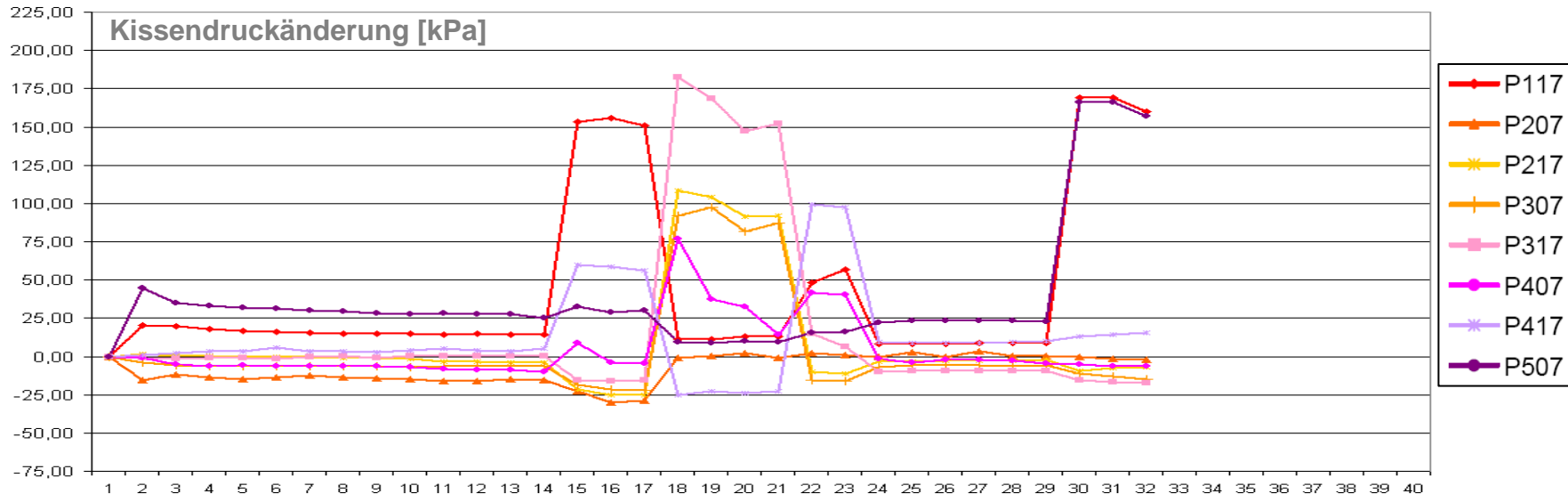

# Kissendruckänderung im Rohrkämpfer

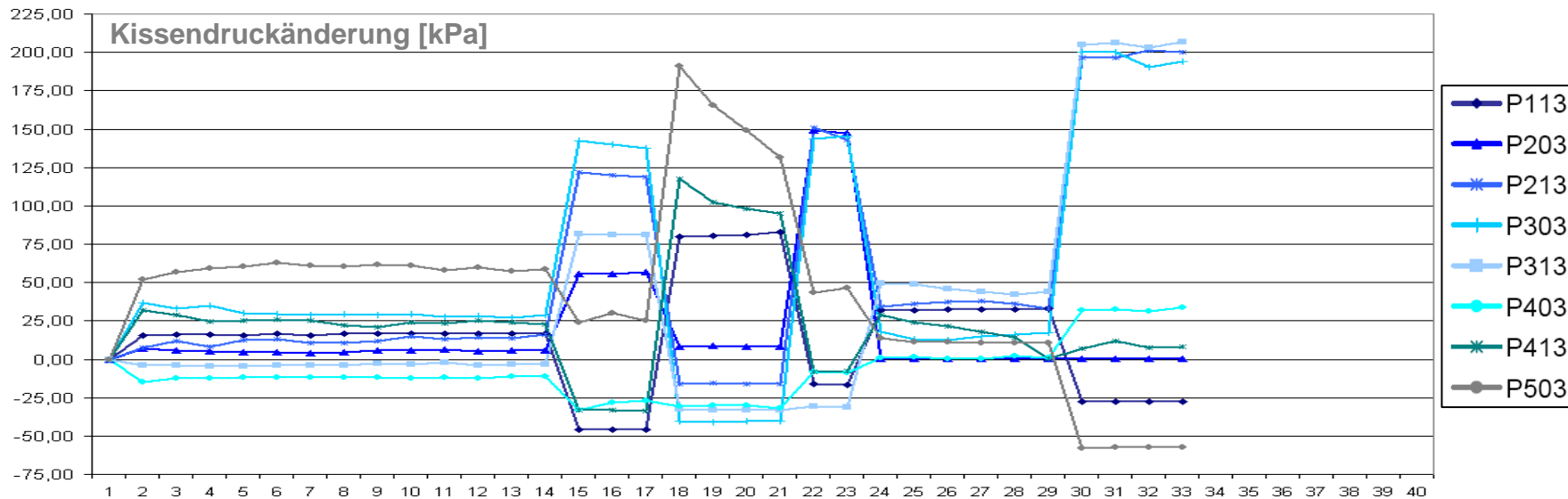
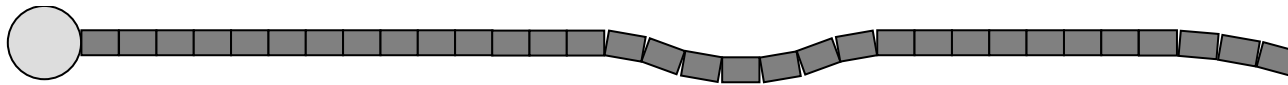
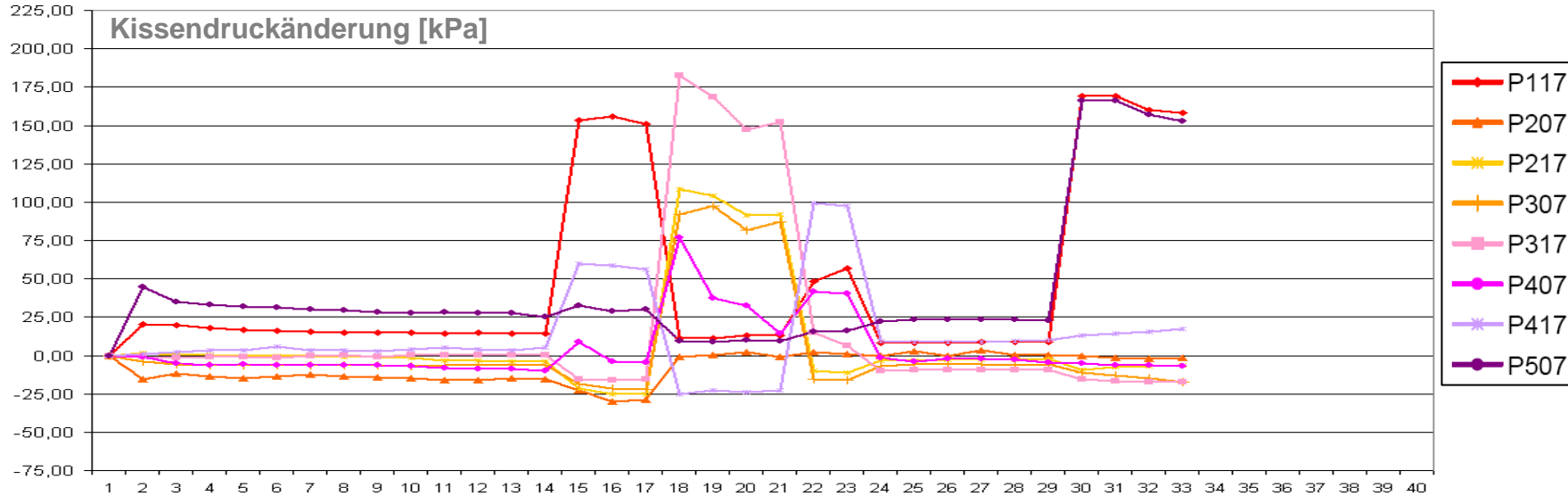

# Kissendruckänderung im Rohrkämpfer

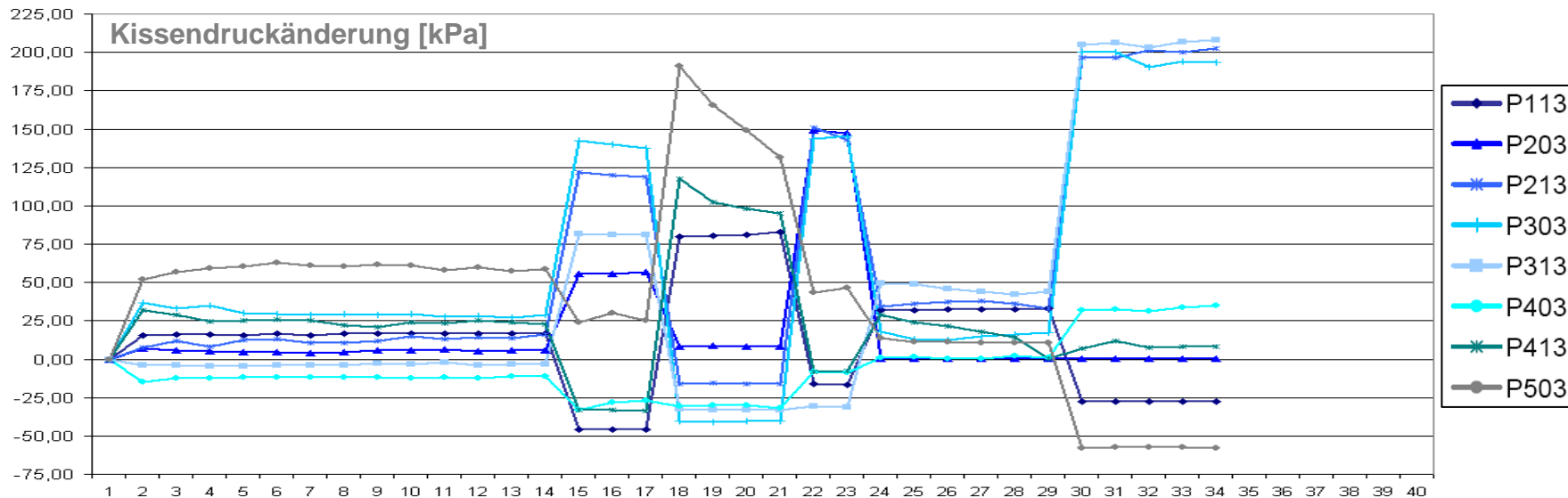
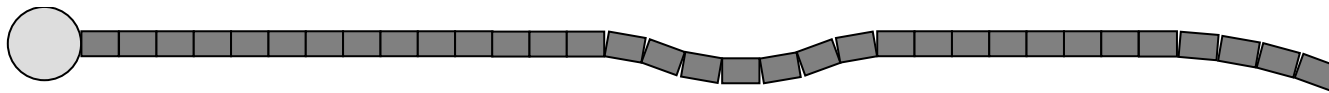
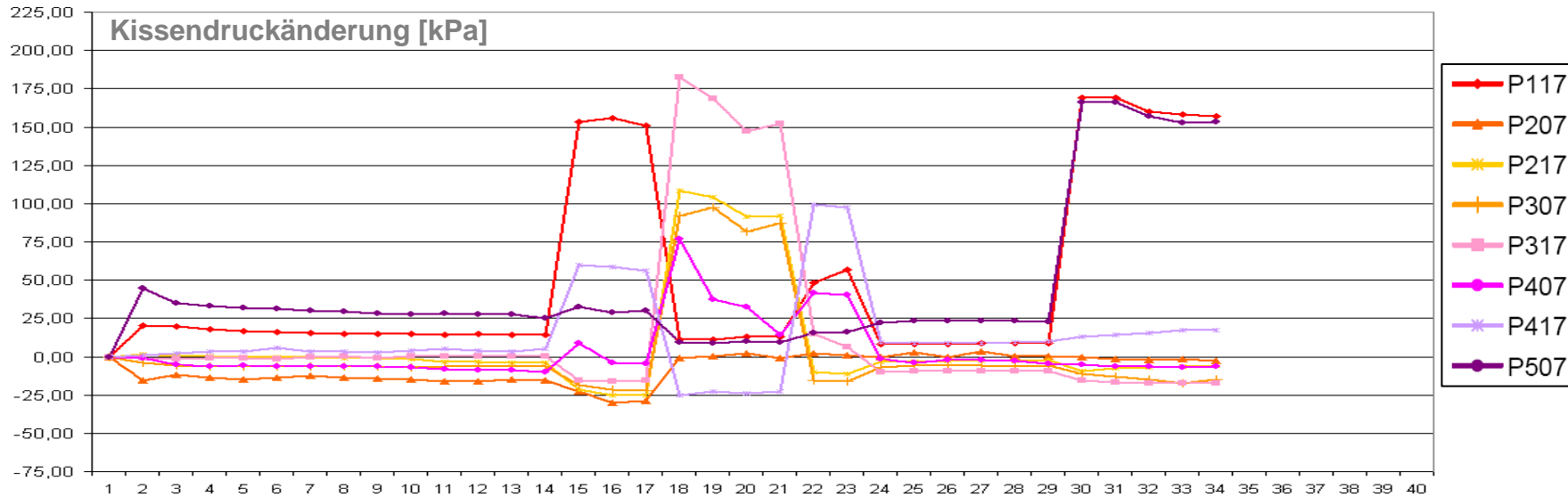

# Kissendruckänderung im Rohrkämpfer

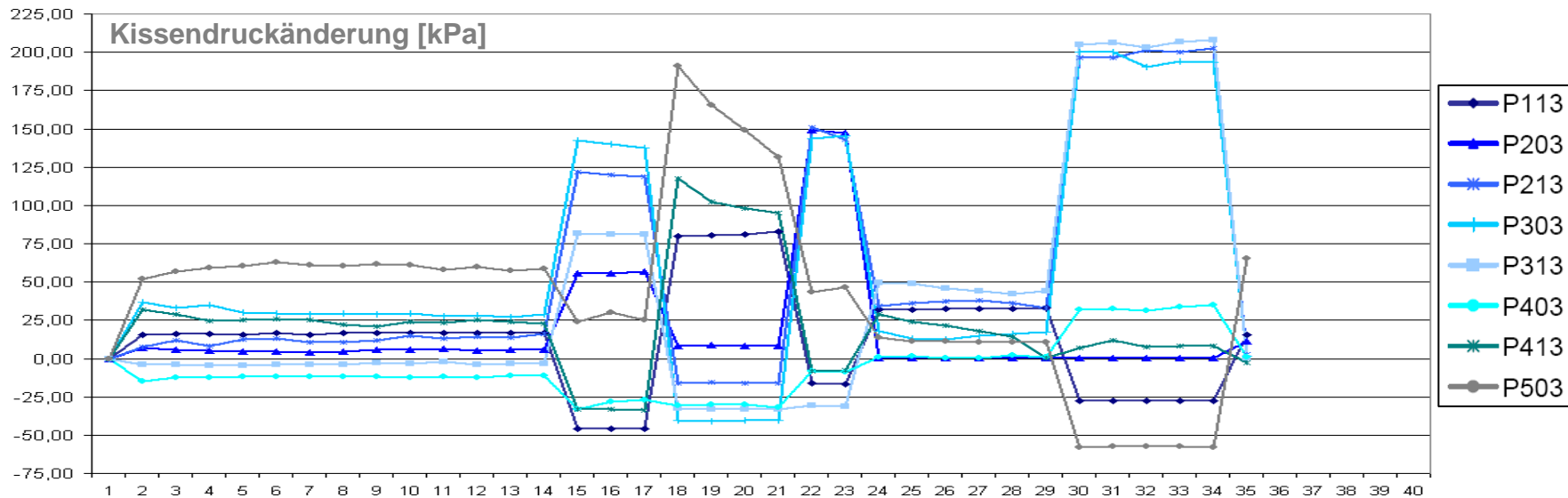
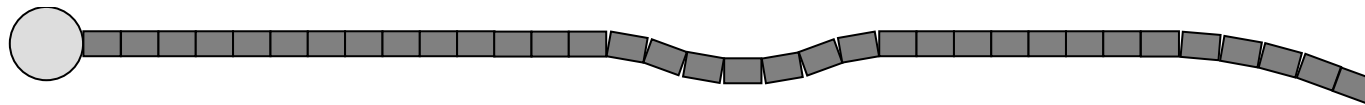
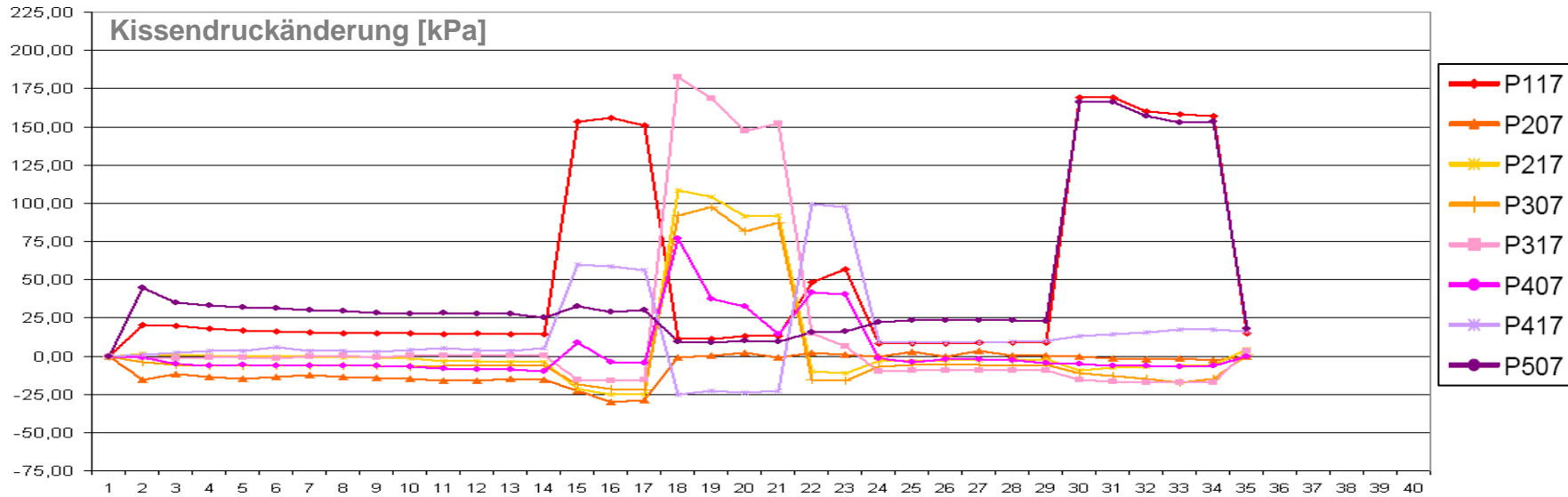



# Kissendruckänderung im Rohrkämpfer

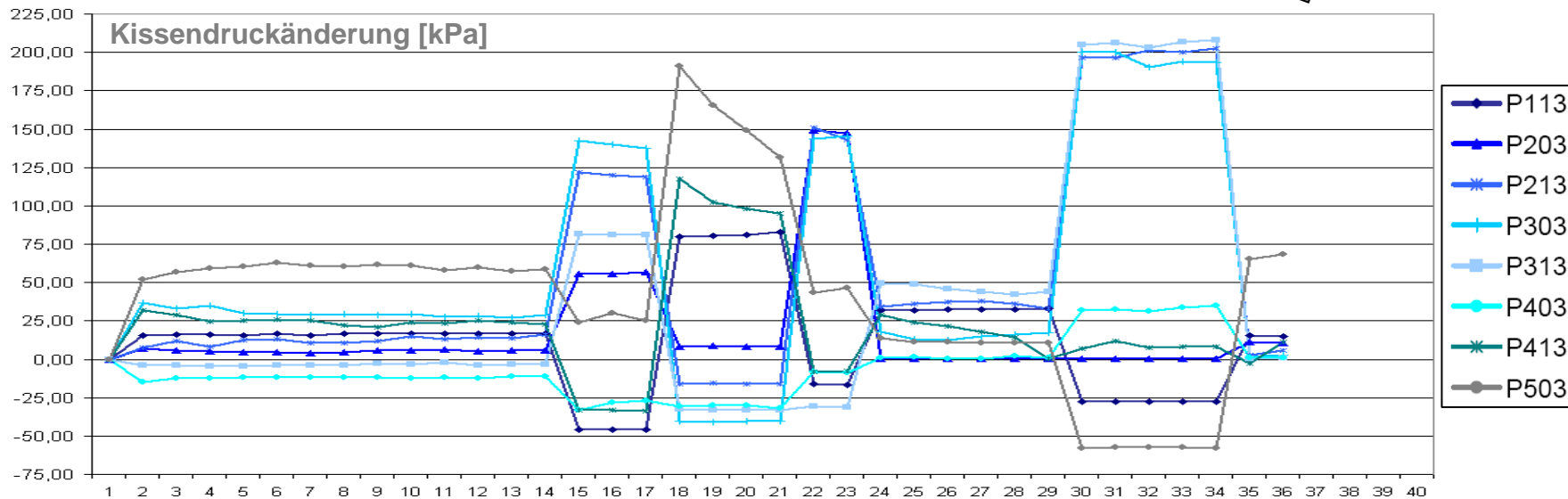
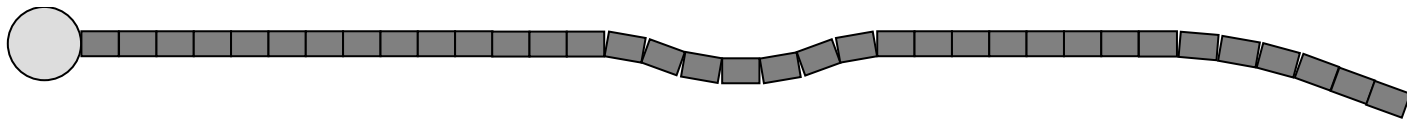
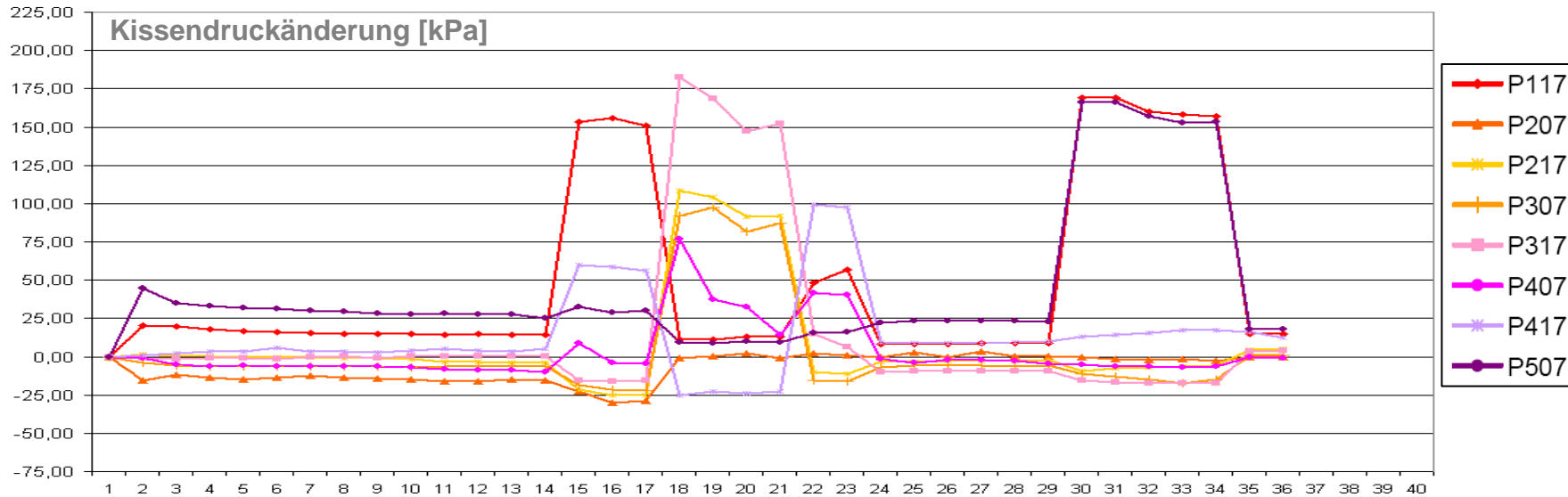



# Kissendruckänderung im Rohrkämpfer

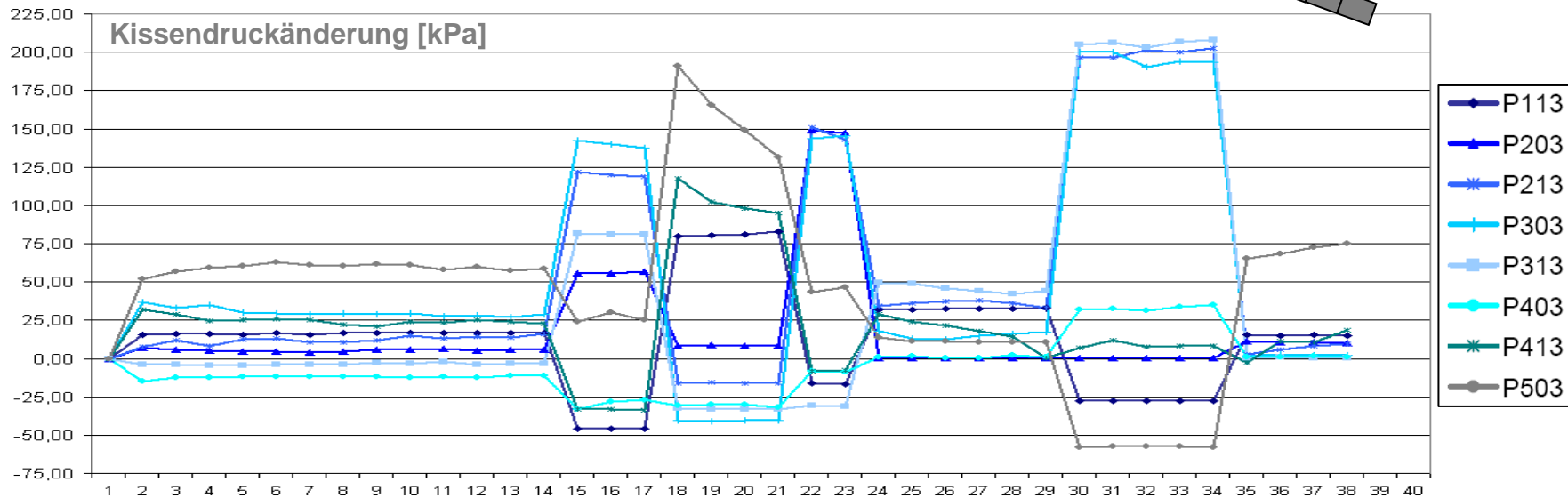
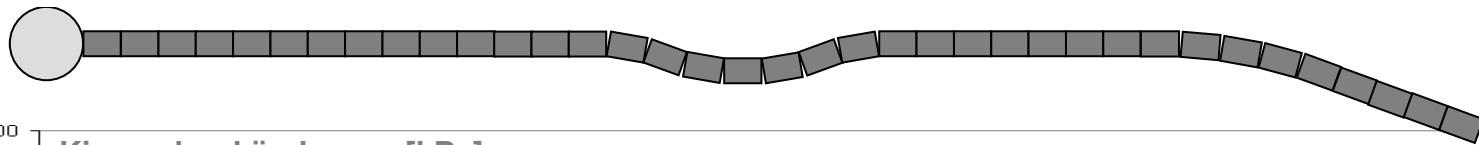
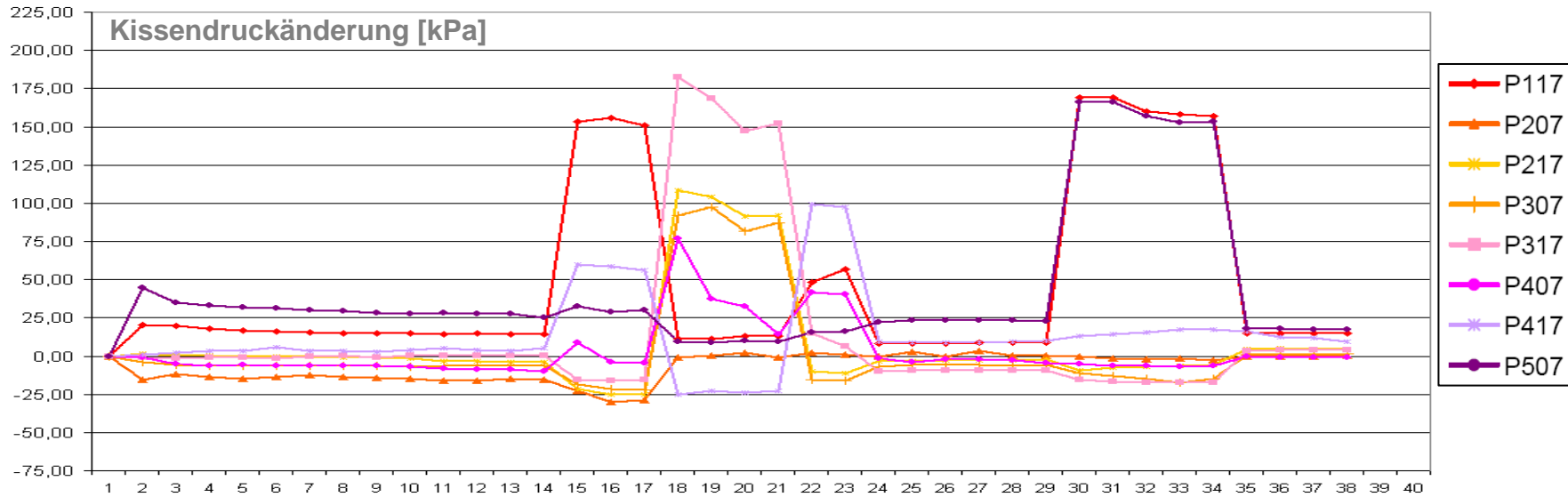



# Kissendruckänderung im Rohrkämpfer

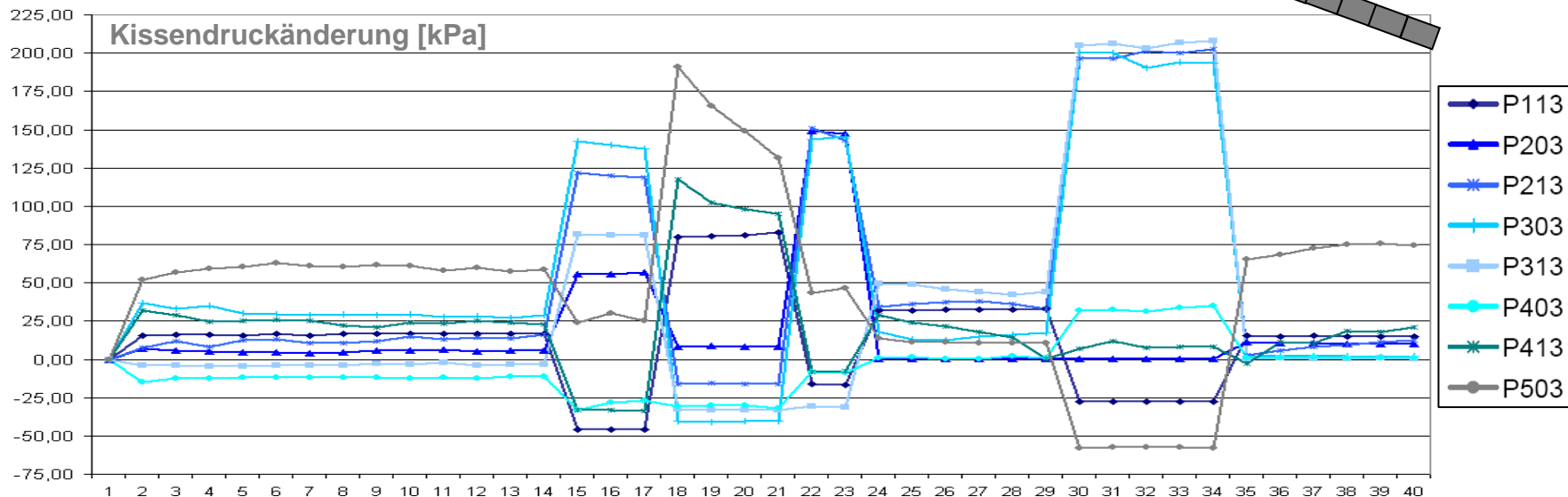
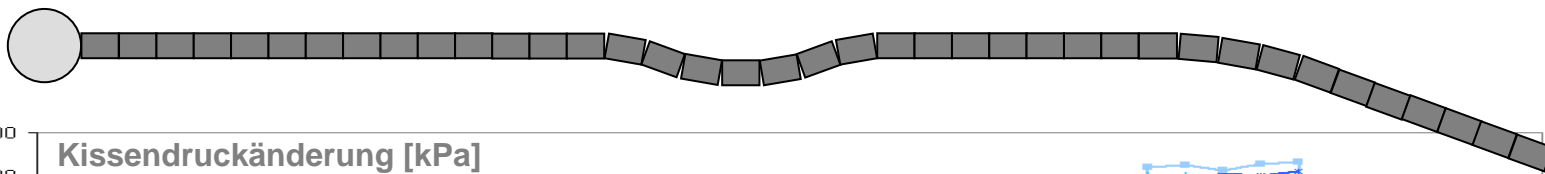
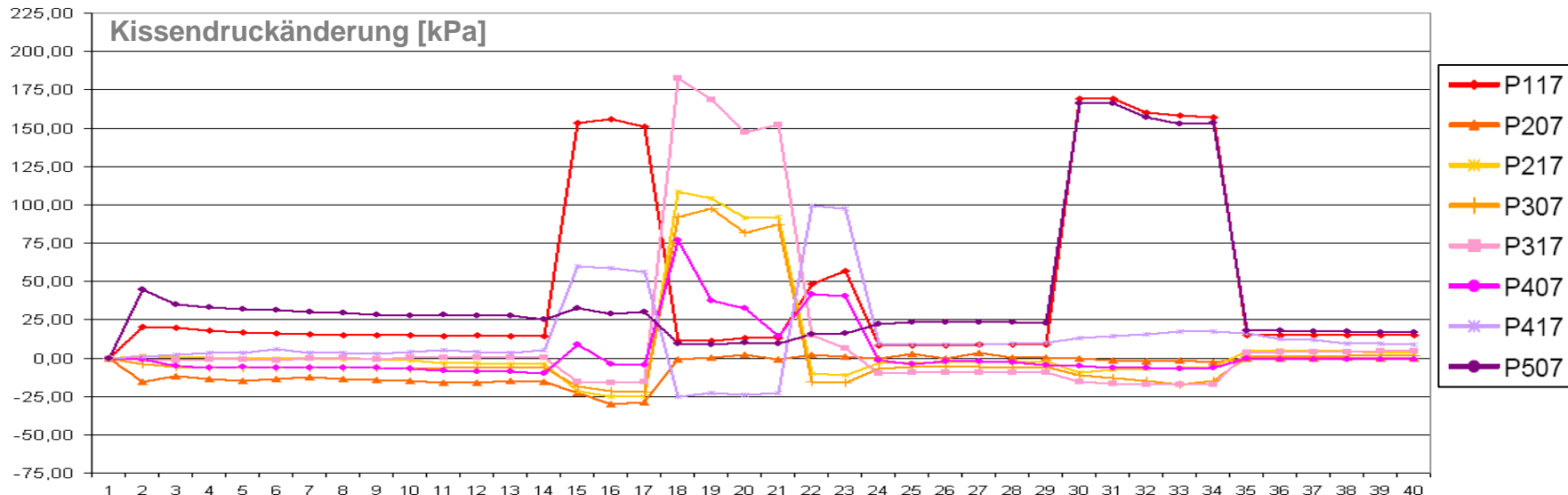

# Bettungsreaktion

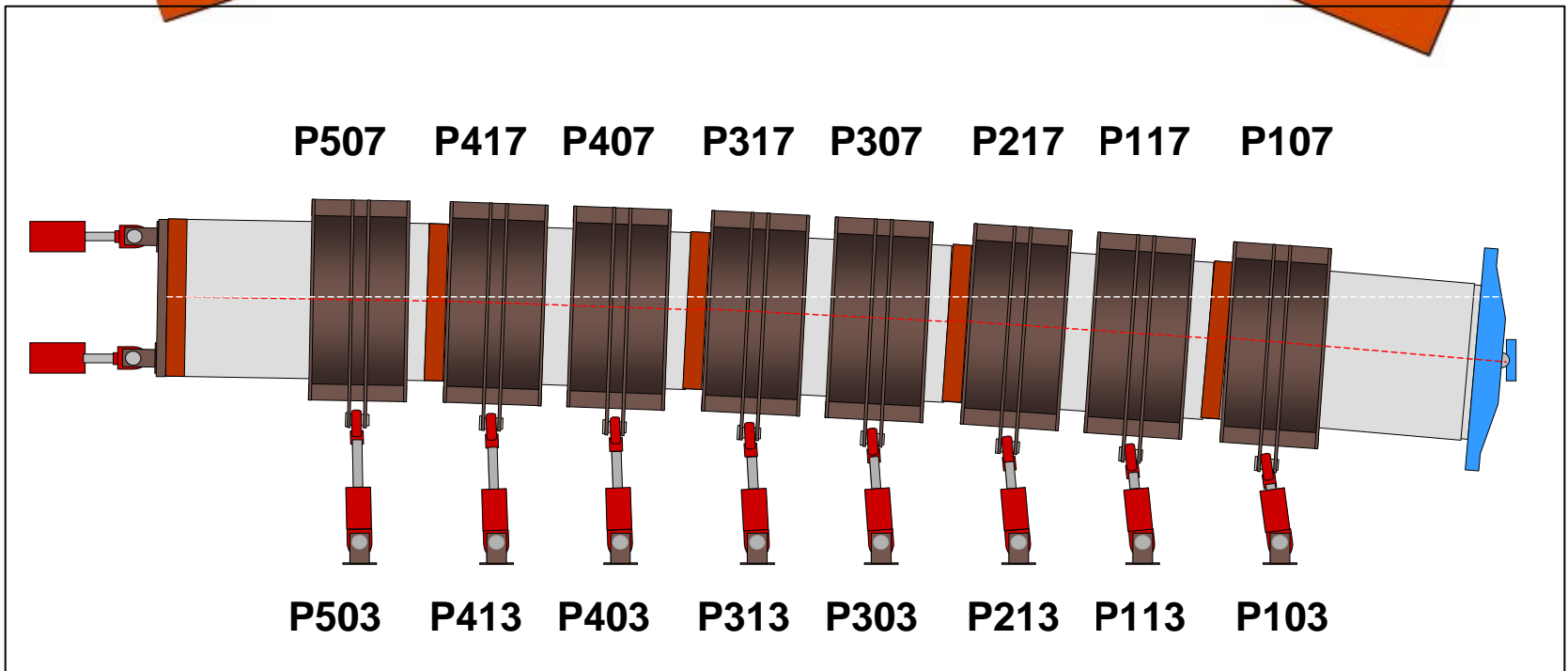
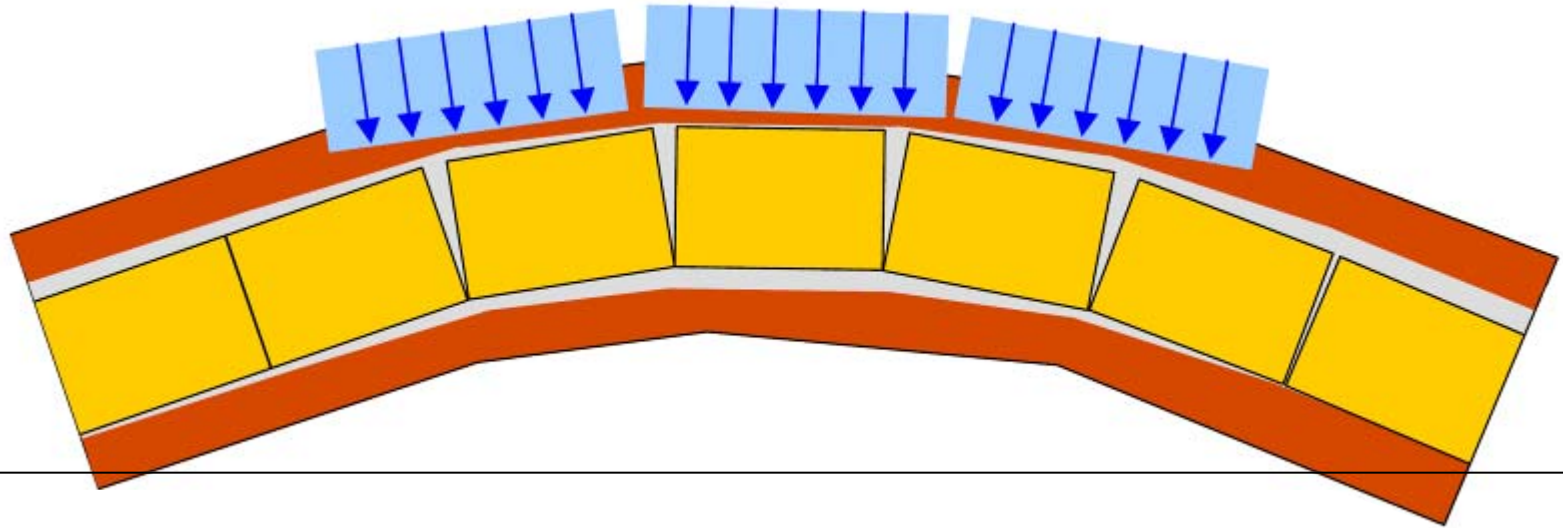

# Rohrkinematik und Bettungsreaktion

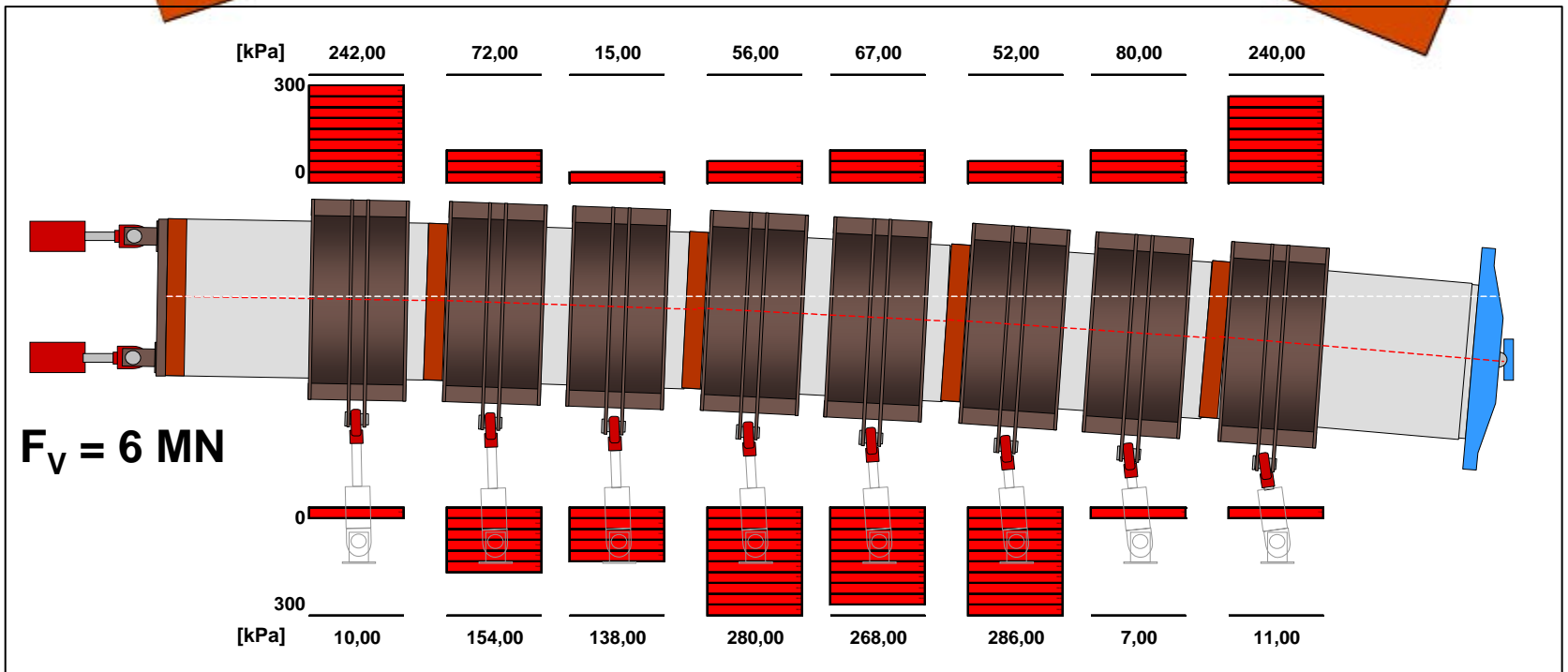
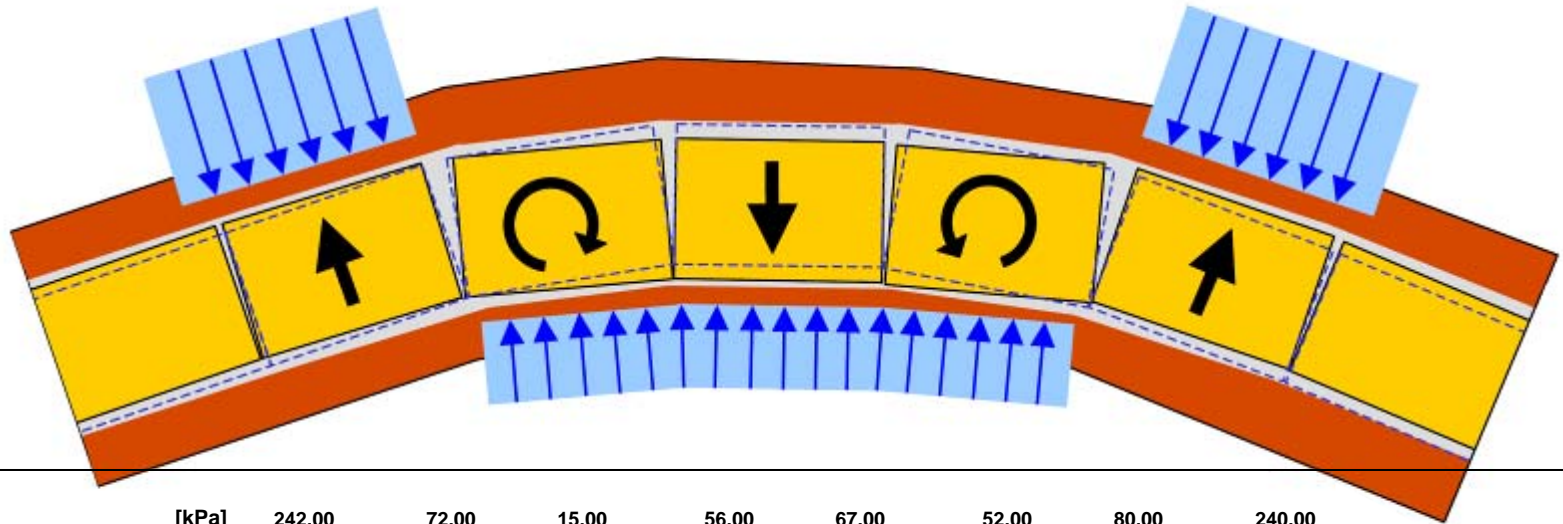

# Lokale Kantenpressung und Querkraftbeanspruchung

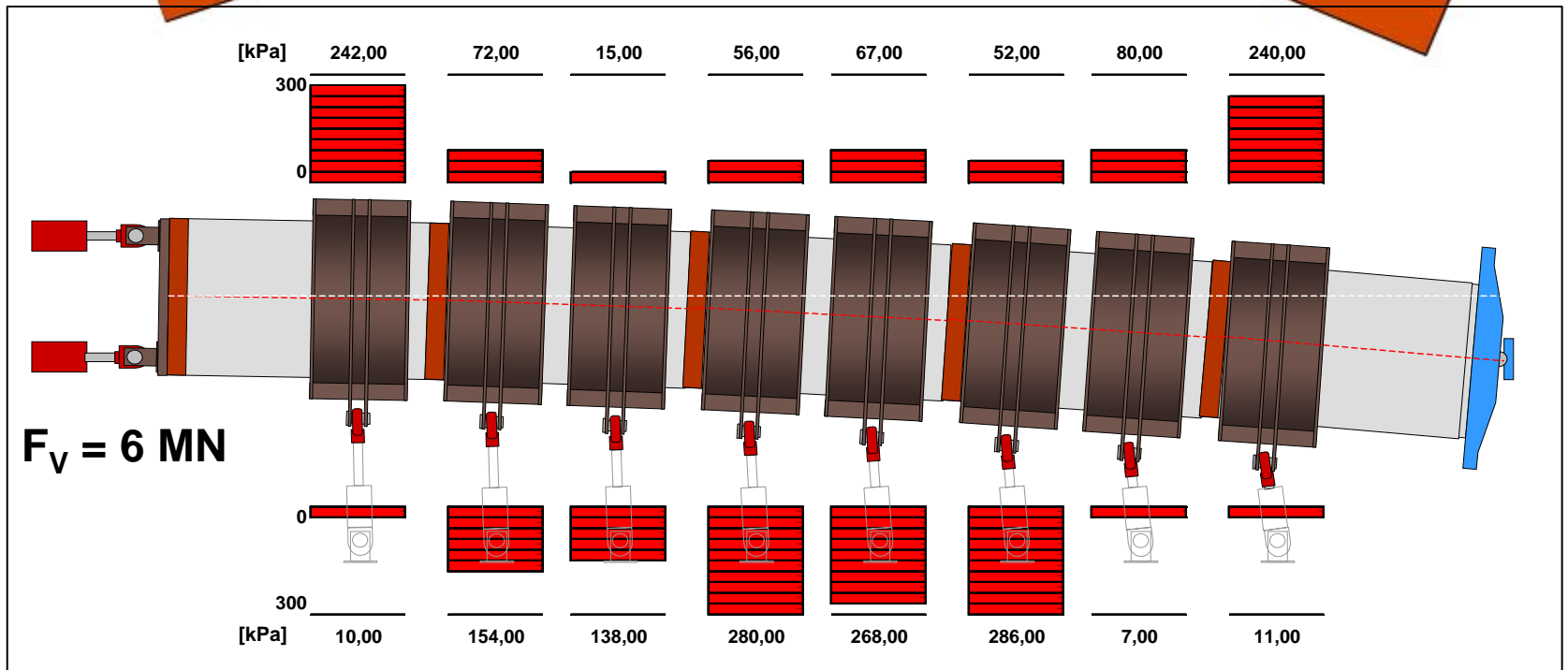
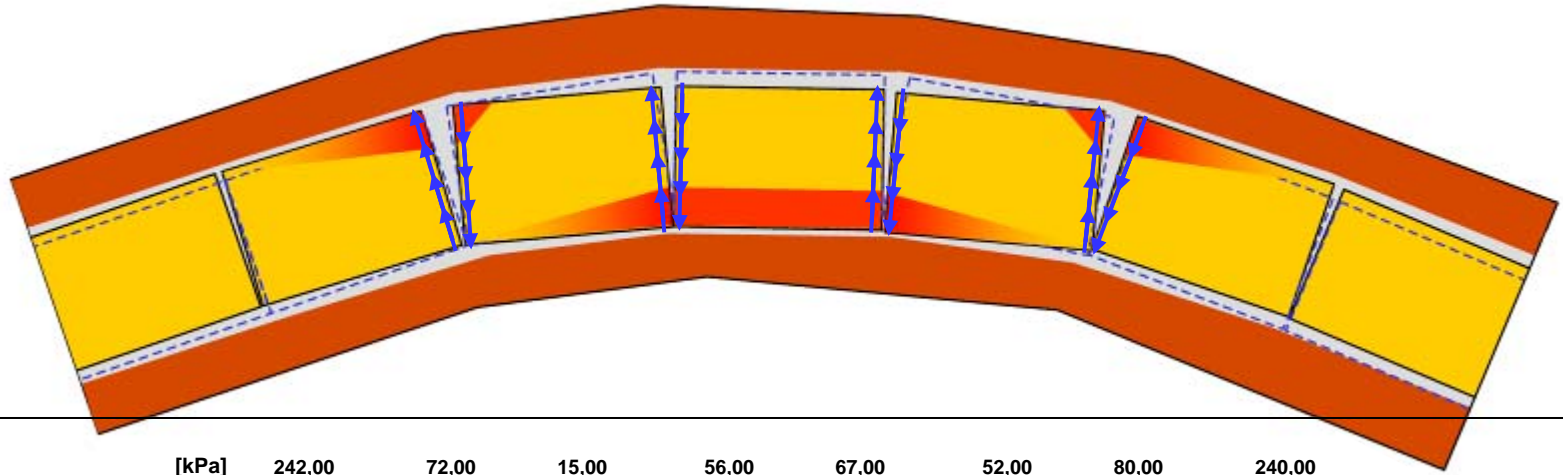



## Rohr-Boden Interaktion während des Rohrvortriebes

G.W.E. Milligan, P. Norris (Universität Oxford, 1999)

### Kontaktfläche an der Kurveninnenseite

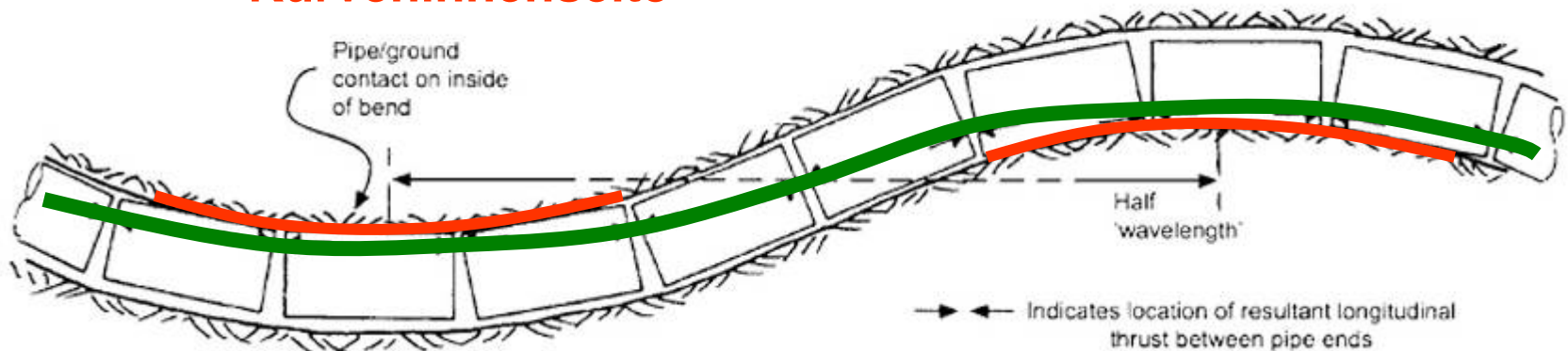

Resultierender Längsdruck  
zwischen den Rohrenden

## Tekscan-Foliensensor-Messsystem

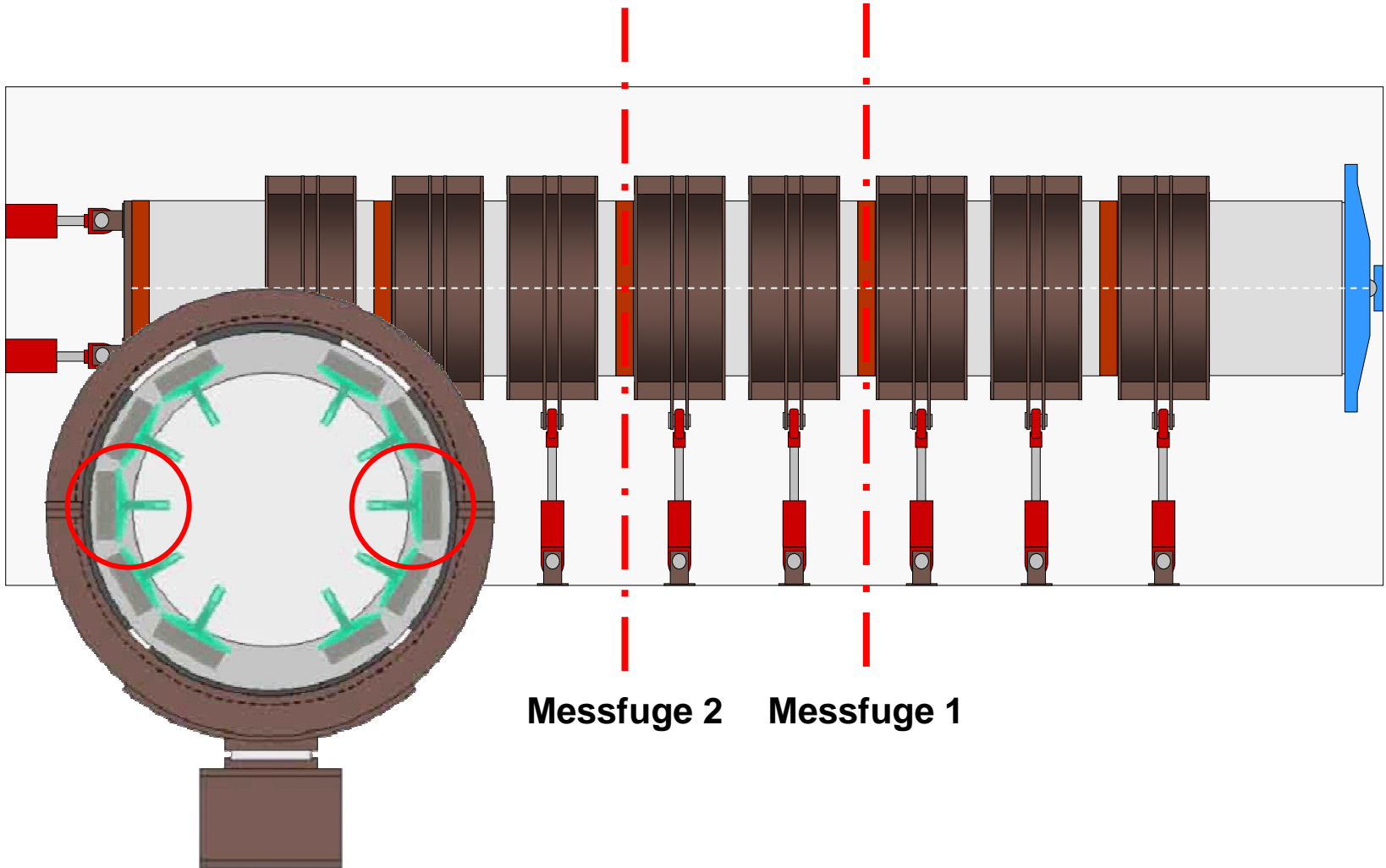

# Spannungsverteilung in der Rohrfuge / Messfuge 2

Holz

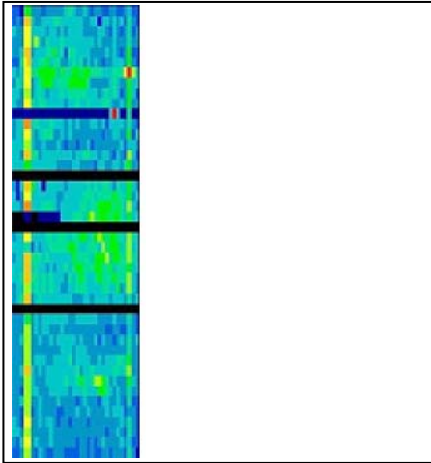

OSB / Spanplatte

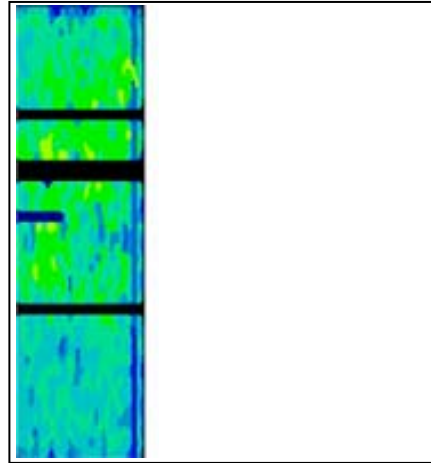

Polyurethan

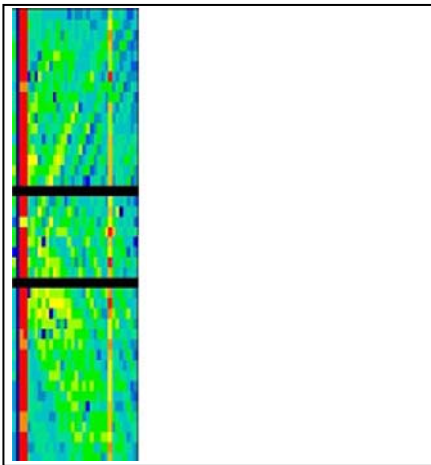
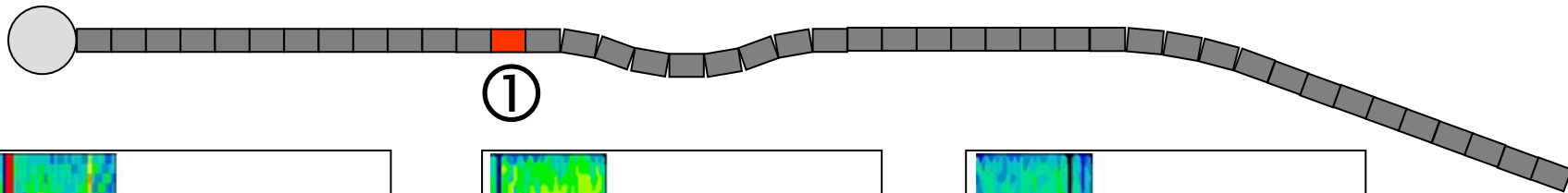
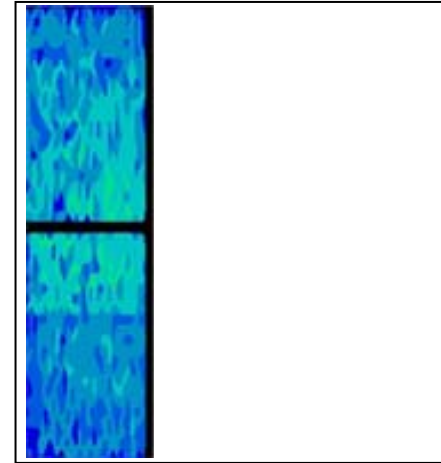

Holz

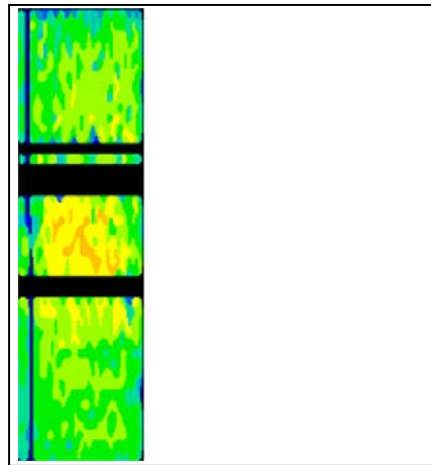

OSB / Spanplatte

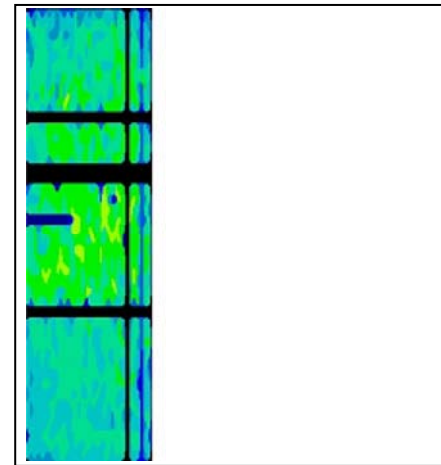

Polyurethan



# Spannungsverteilung in der Rohrfuge / Messfuge 2

Holz

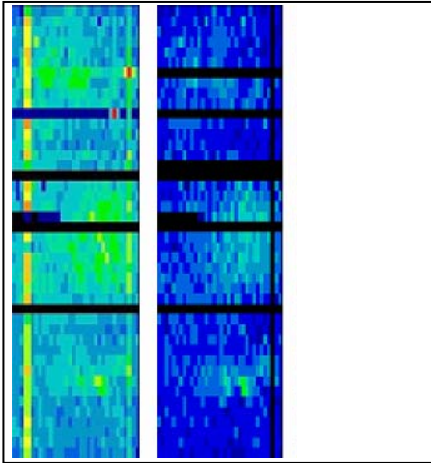

OSB / Spanplatte

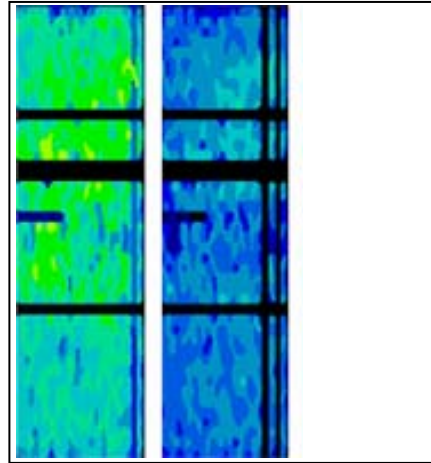

Polyurethan

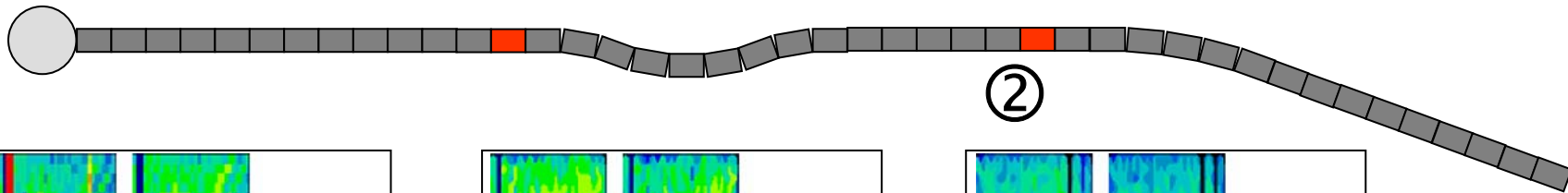
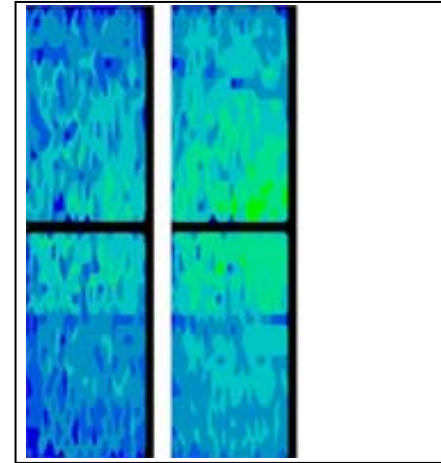

Holz

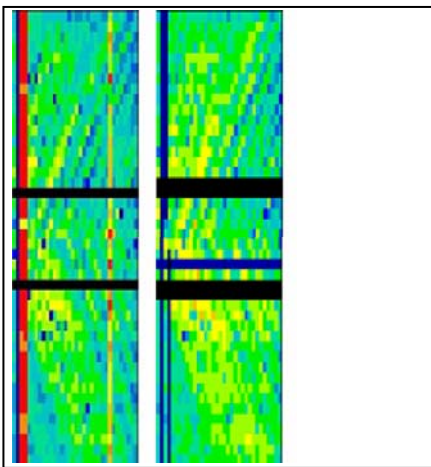

OSB / Spanplatte

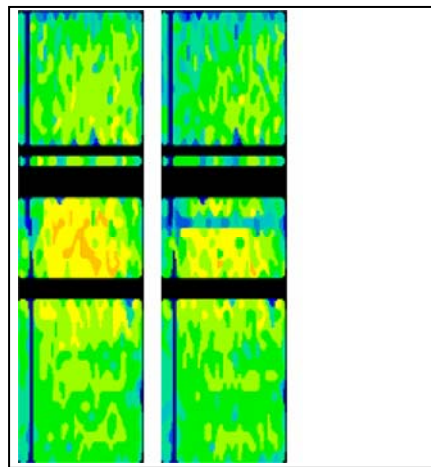

Polyurethan

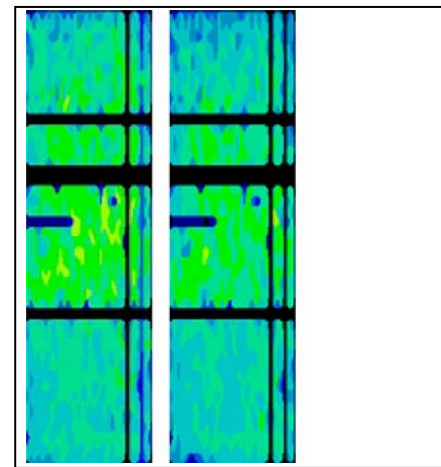

# Spannungsverteilung in der Rohrfuge / Messfuge 2

Holz

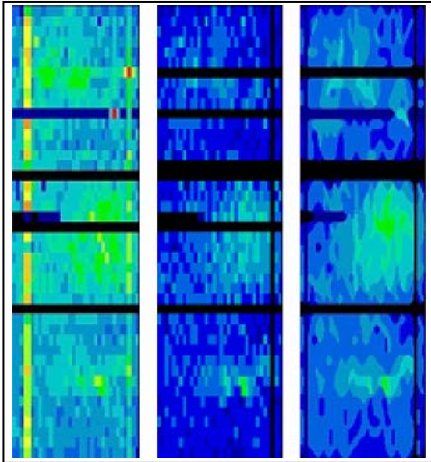

OSB / Spanplatte

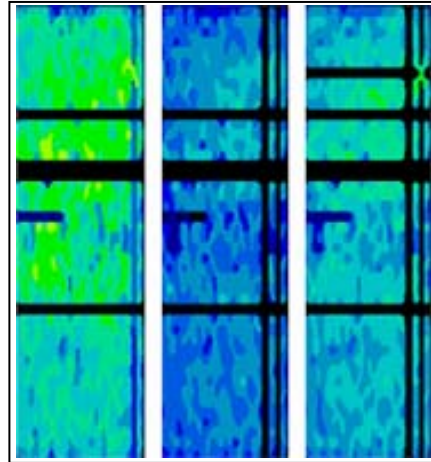

Polyurethan

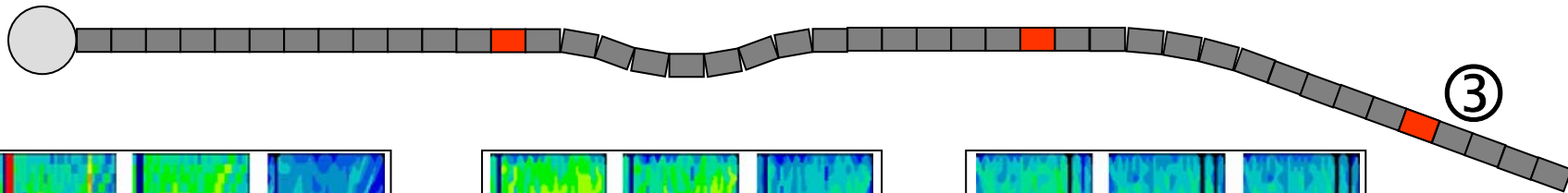
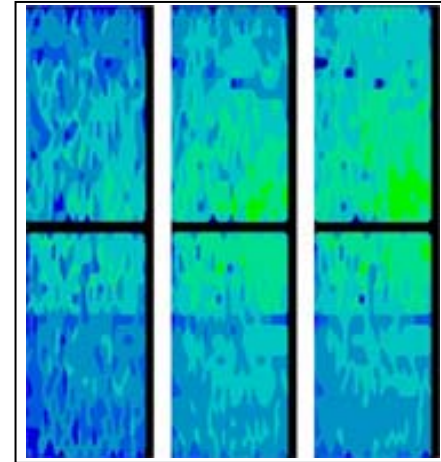

Holz

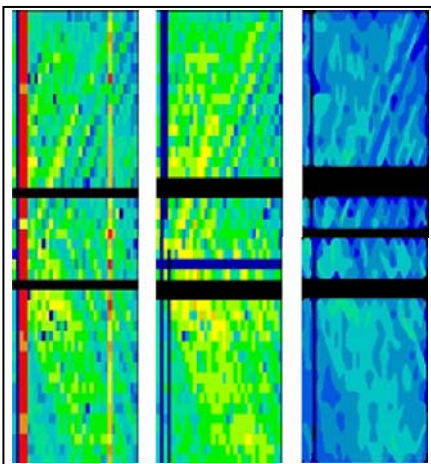

OSB / Spanplatte

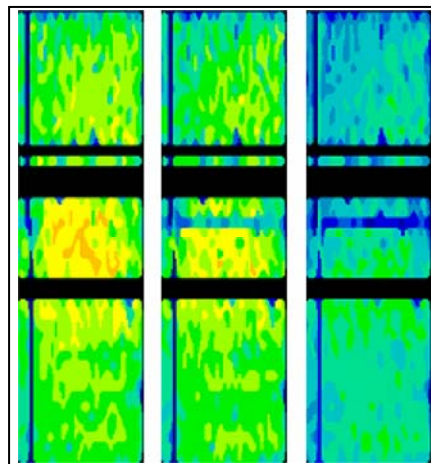

Polyurethan

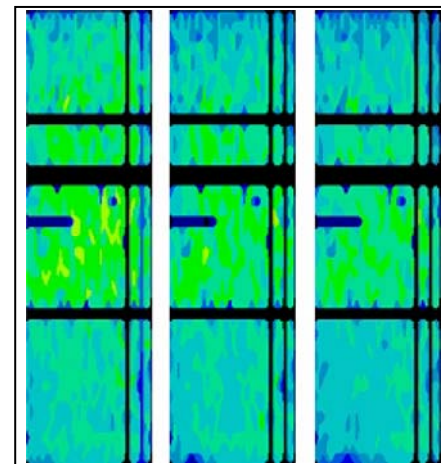

# Rohrspiegel





Tachymeter - Vermessung

## FaroArm<sup>®</sup> Messsystem - Genauigkeit bis zu $\pm 0,005$ mm



**Weitere Alternative: Laser-Tracker**



## Spitzende Rohr Nr. 1

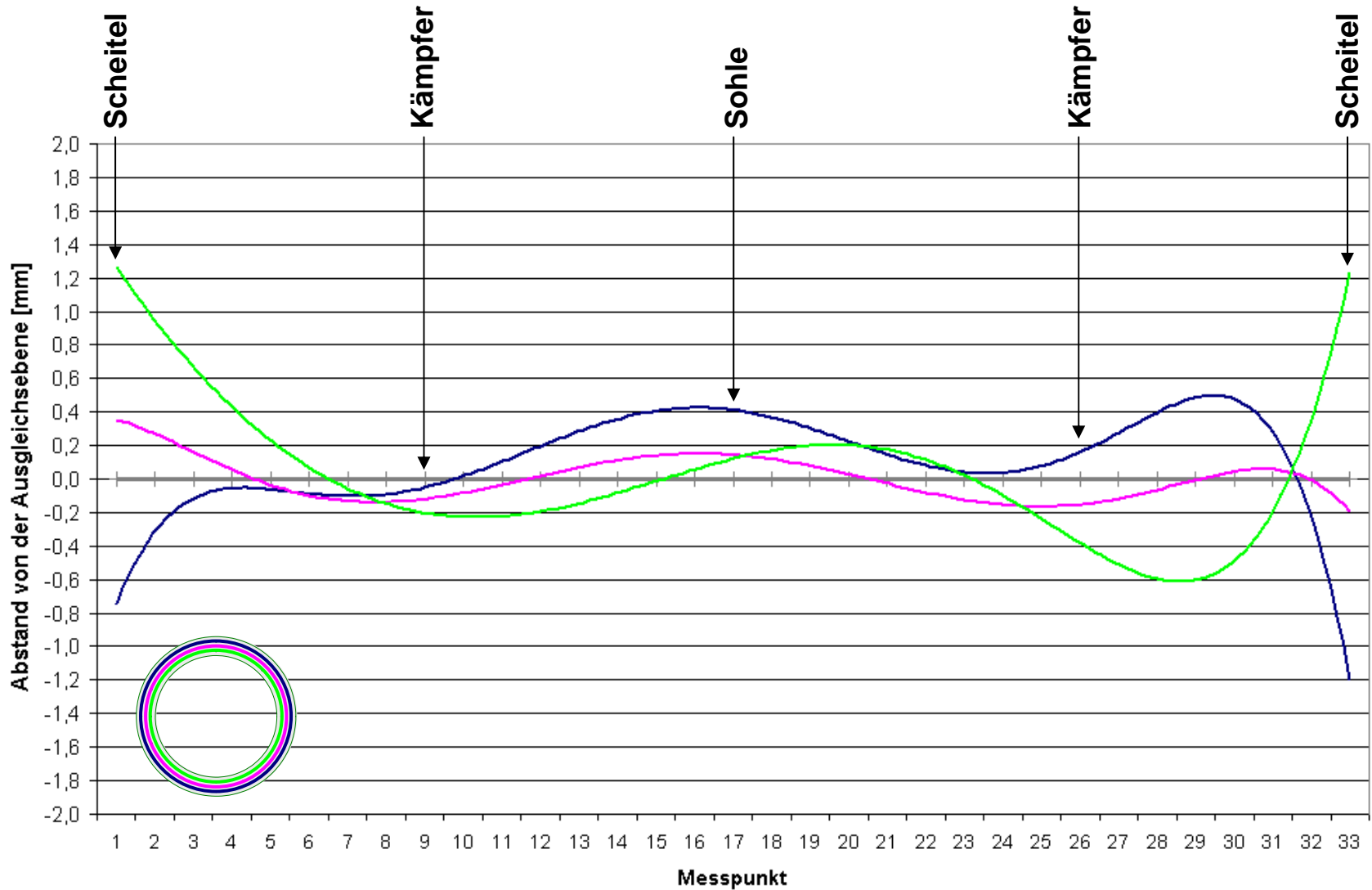

## Muffe Rohr Nr. 1

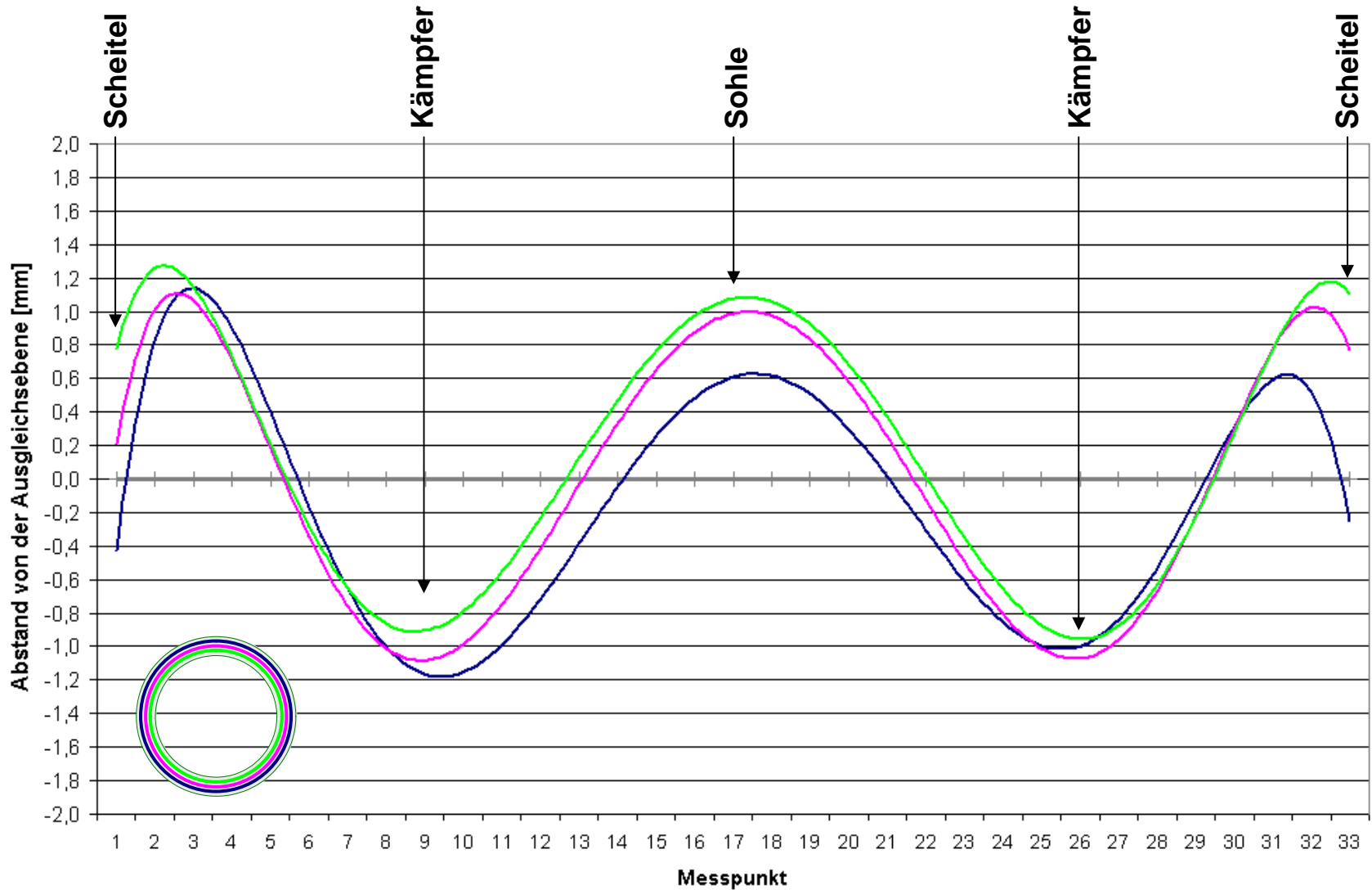

## Spitzende Rohr Nr. 2

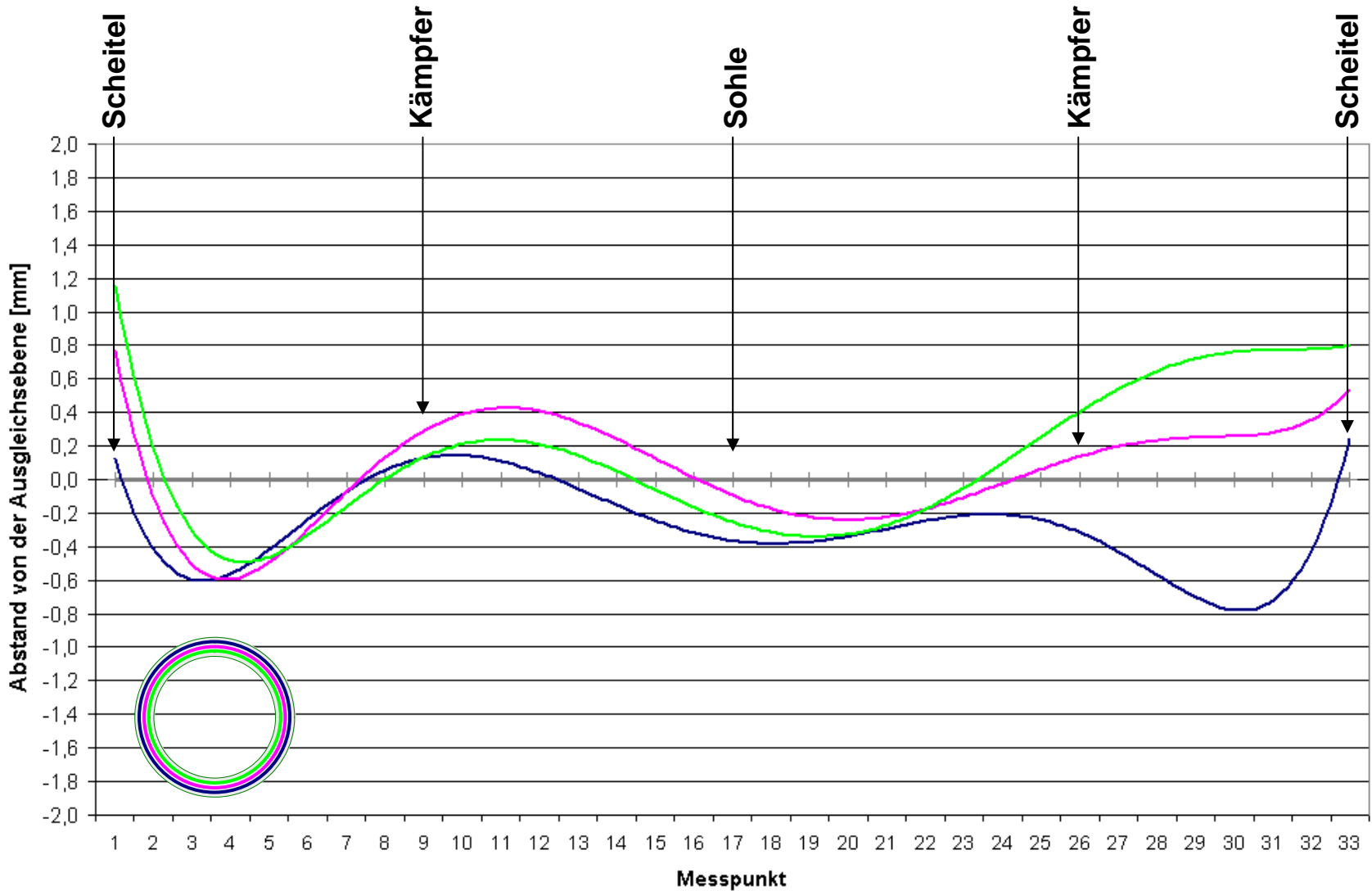

## Muffe Rohr Nr. 2

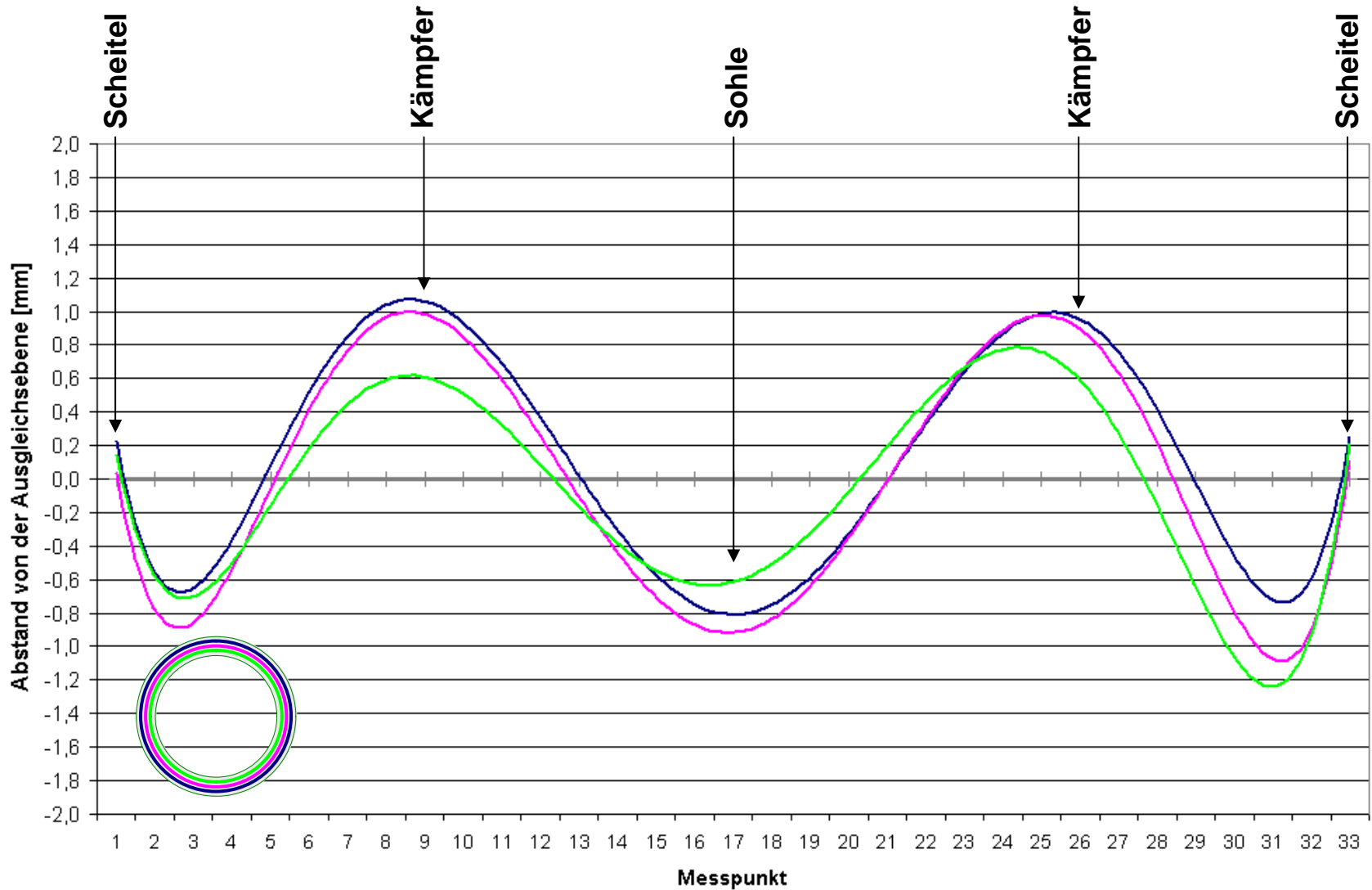

## *Muffe Rohr Nr. 2*

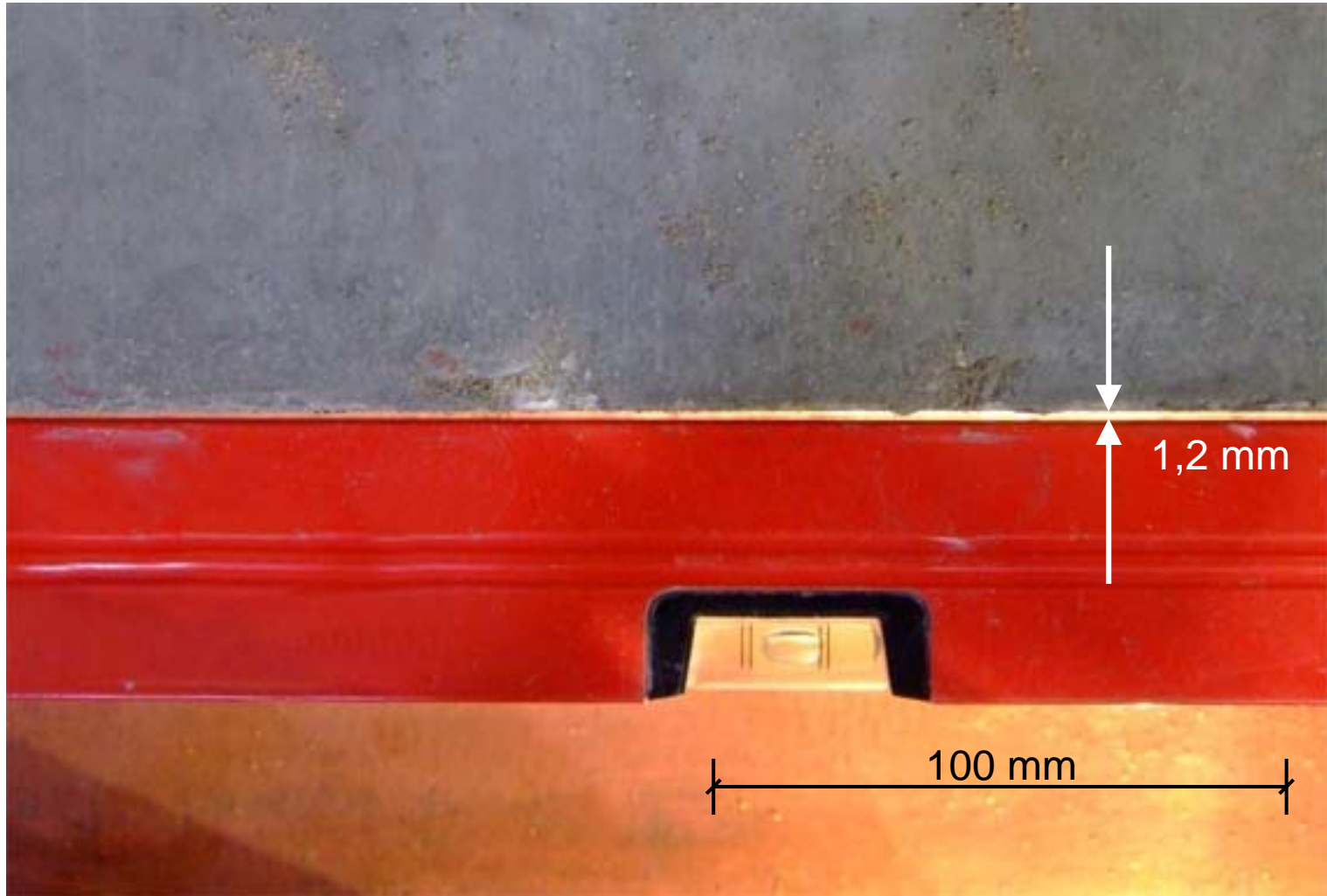

# ***IKT-Vortriebssimulator: Schlussfolgerungen***

**Keine Ideal-Kinematik bei Kurvenfahrten**

**Erheblicher Einfluss des Druckübertragungsmittels**

**Signifikante Querkräfte bei gekrümmten Trassen**

**Zusätzliche Mantelreibung in Kurven**

**Einfluss von Imperfektionen der Rohre**

1. Hintergrund
2. Vortriebssimulator
3. Auswertung
- 4. Ausblick**



# Rohrstrangvermessung von Hand





## *Fugenspaltmessung*



# Rohrstrangvermessung von Hand

Spaltbreite 64,4 mm

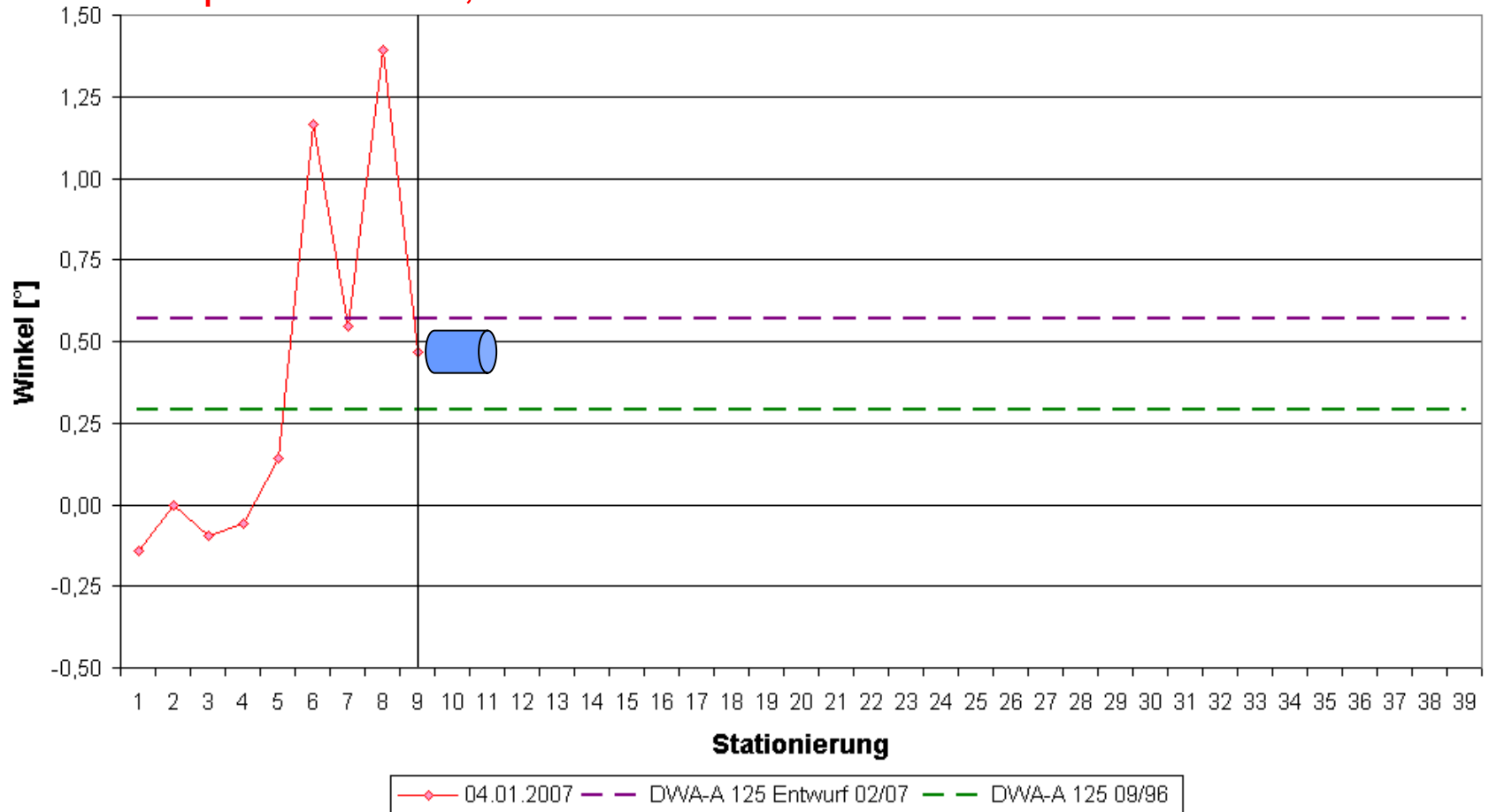

**Startschacht**



# Rohrstrangvermessung von Hand

Spaltbreite 61,3 mm

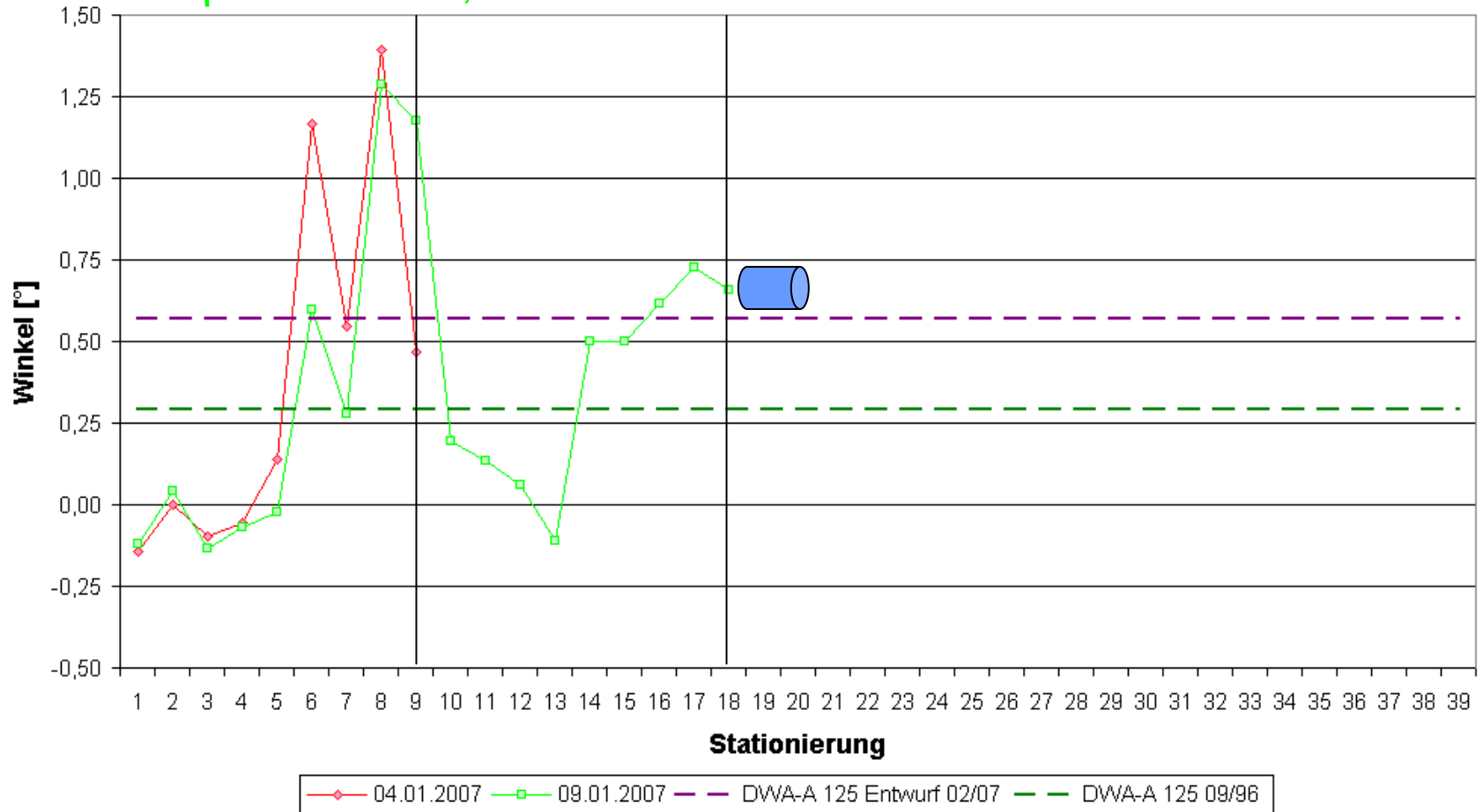

Startschacht



# Rohrstrangvermessung von Hand

Spaltbreite 61,0 mm

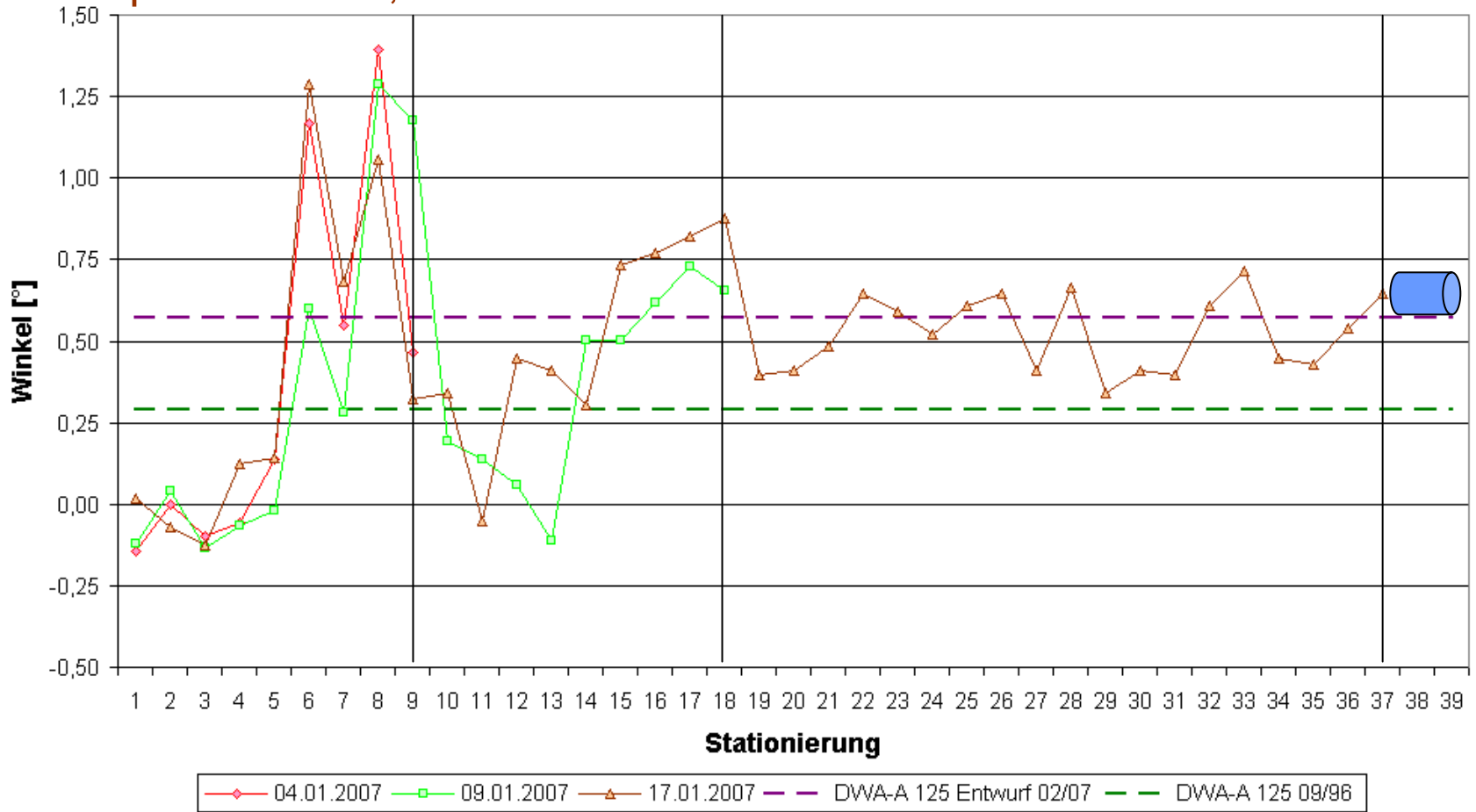

Startschacht



# Rohrstrangvermessung von Hand

Spaltbreite 69,0 mm

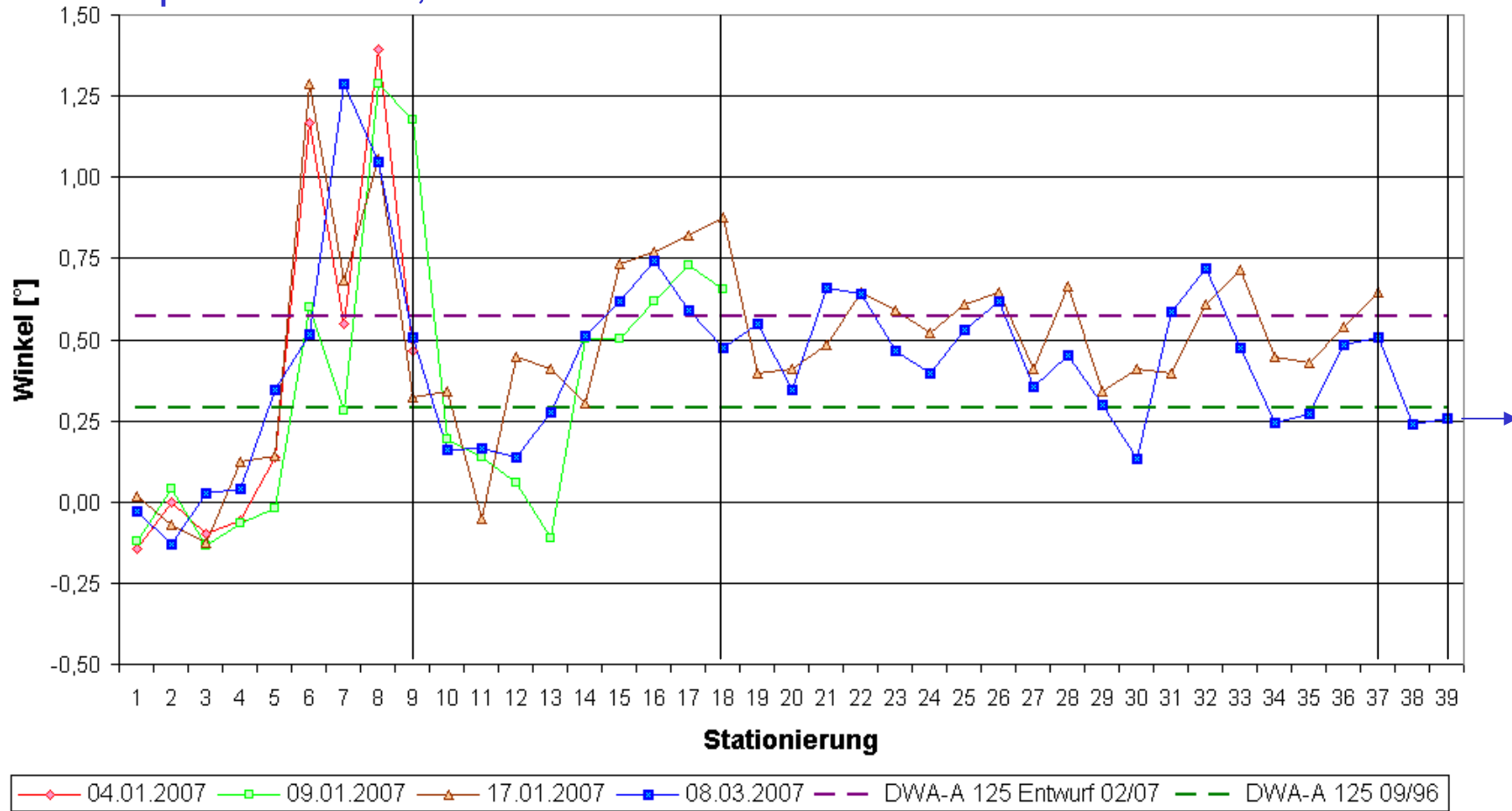

Startschacht



## Kapazitives Messsystem

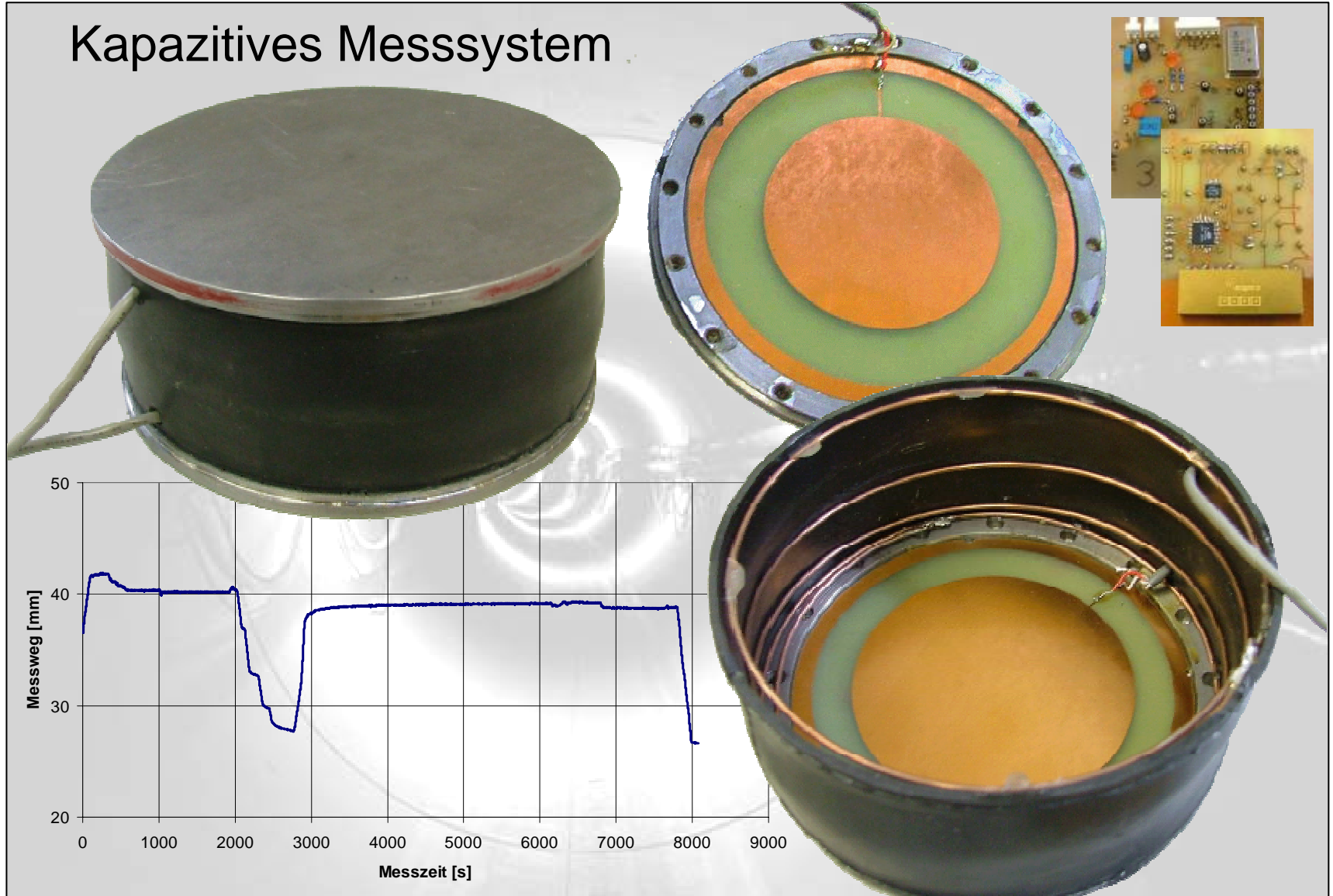

- ◆ **Stichprobenartige Rohrvermessung**
- ◆ **Stichprobenartige Rohrstrangvermessung**
- ◆ **Druckübertragungsmitteluntersuchung**
- ◆ **Kontinuierliche Vermessung ausgewählter Rohrverbindungen**
- ◆ **Endvermessung fertiggestellter Rohrstrang**
- ◆ **Auswertung der Vorpresskräfte**
- ◆ **Abnahmebegehung**

**Ihr Ansprechpartner:**

**Dipl.-Ing. Martin Liebscher**

**IKT-Institut für Unterirdische  
Infrastruktur**

**Exterbruch 1**

**45886 Gelsenkirchen**

**Tel.: +49-209-17806-23**

**E-Mail: [liebscher@ikt.de](mailto:liebscher@ikt.de)**



[www.ikt.de](http://www.ikt.de)

